



**TADANO**

タダノ オールテレーンクレーン

# ATF130G-5 型

仕 様 書

キャリヤ : FAUN ATF130G-5

スペック番号 : ATF-130G-1-90101

**株式会社 タダノ**

管理番号 JA-02

# ATF130G-5型 130 t オールテレーンクレーン

## 1. 主要諸元

### ◎ クレーン

クレーン容量

ブーム	12.8 mブーム	130,000 kg ×	2.7 m (2×12本掛、アタッチメント付)
	17.1 mブーム	86,900 kg ×	4.0 m (13本掛)
	21.4 mブーム	86,900 kg ×	4.0 m (13本掛)
	25.8 mブーム	70,000 kg ×	5.0 m (11本掛)
	30.1 mブーム	54,300 kg ×	4.5 m (8本掛)
	34.4 mブーム	44,000 kg ×	5.0 m (7本掛)
	38.7 mブーム	32,800 kg ×	7.0 m (5本掛)
	43.0 mブーム	27,100 kg ×	9.0 m (4本掛)
	47.4 mブーム	21,400 kg ×	11.0 m (3本掛)
	51.7 mブーム	16,600 kg ×	12.0 m (3本掛)
	56.0 mブーム	13,200 kg ×	14.0 m (3本掛)
	60.0 mブーム	10,600 kg ×	16.0 m (3本掛)
	シングルトップ	7,300 kg	(1本掛)

ハイフォルト <sup>®</sup> ハワチルトジブ	3.8 m ジブ	40,000 kg ×	4.0 m (6本掛)
	10.2 m ジブ	14,600 kg ×	14.0 m (2本掛)
	18.0 m ジブ	7,800 kg ×	6.0 m (2本掛)

最大地上揚程	ブーム	61.0 m
	ハイフォルト <sup>®</sup> ハワチルトジブ	78.0 m

最大作業半径	ブーム	56.0 m
	ハイフォルト <sup>®</sup> ハワチルトジブ	64.0 m

ブーム長さ	12.8 m ~ 60.0 m
ブーム伸縮長さ	47.2 m
ブーム伸長時間	47.2 m / 400 s
主巻ロープ巻上げ速度	120 m/min (4層)
主巻フック巻上げ速度	9.2 m/min (13本掛)
補巻ロープ巻上げ速度	120 m/min (4層)
補巻フック巻上げ速度	120 m/min (1本掛)
ブーム起伏角度	-1.0° ~ 82.7°
ブーム上げ速度	-1.0° ~ 82.7° / 50 s

旋 回 角 度		360° 連続
旋 回 速 度		1.4 min <sup>-1</sup>
ワイヤロープ	主 補	径 21 mm × 長さ 360 m
		径 21 mm × 長さ 250 m
フ ッ ク		90 t 吊 (13 本掛)
		50 t 吊 (7 本掛)
		22 t 吊 (3 本掛)
		7.3 t 吊 (1 本掛)
ブ ー ム 形 式		箱型 6 段油圧伸縮式
		各段ピンロック方式
ブ ー ム 伸 縮 装 置		複動油圧シリンダ直押式 1 本
ジ ブ 形 式		ラチス型 2 段 + 箱形 1 段
		オフセット 5° ~ 40° 油圧無段階傾斜式
シ ン グ ル ト ッ プ		先端ブーム取付横折曲格納式
巻 上 装 置		油圧モータ駆動遊星歯車減速式
		自動ブレーキ
		シングルウインチ 2 基
ブ ー ム 起 伏 装 置		複動油圧シリンダ直押式
ジ ブ チ ル ト 装 置		複動油圧シリンダ直押式
旋 回 装 置		油圧モータ駆動遊星歯車減速式
		ボール式スイングベアリング
		手動スイッチ式ブレーキ
		手動操作式旋回ロック
カ ウ ン タ ウ エ イ ト		40 t、28 t、25 t、15 t、6t
ア ウ ト リ ガ		全油圧式 H 型
		スライド・ジャッキ各個操作装置付
		最大張出幅 7.5m
		中間張出幅 6.2m、5.0m、4.1m
		スライドロック用ピン付
		スライド格納式フロート
動 力 取 出 方 式		上部専用エンジン
	名 称	OM904LA (ベンツ製)
	形 式	水冷 4 サイクル 直列 4 気筒
		直接噴射式 排気ターボ過給
		インタークーラ付 ディーゼルエンジン
	総排気量	4.25 L
	最高出力	129 kW {175PS} / 2,200 min <sup>-1</sup> {rpm}
	最大トルク	675 N·m {68kgf·m} / 1,200 min <sup>-1</sup> {rpm}
燃 料 タ ン ク		220 L

油 圧 ポ ン プ	高圧可変 <sup>レ</sup> ストポン <sup>プ</sup> 2個 +高圧 <sup>レ</sup> ストポン <sup>プ</sup> 1個 +高圧ギヤ <sup>レ</sup> ポン <sup>プ</sup> 2個
作 動 油 タ ン ク 容 量	785 L
安 全 装 置	過負荷防止装置 (AML) 作業範囲制限機能付 フック移動量表示機能付 旋回範囲制限機能 アウトリガ張出幅自動検出装置 (個別検出式) 旋回自動停止機能 ブーム起伏緩停止機能 巻過防止装置 捨巻確保装置 水準器 玉掛けロープはずれ止め 旋回ロック装置 油圧安全弁 油圧ロック装置 (伸縮・起伏・巻上・ジャッキ)
付 属 装 置	カウンタウエイト着脱装置 ブーム起伏微速モード設定装置 旋回微速モード設定装置 ジブチルト微速モード設定装置 巻上微速モード設定装置 ブーム着脱装置 AML外部表示灯 風速計 オイルクーラー クレーンキャブエアコン AM・FMラジオ ドラム視認モニター 旋回音声警報装置 リフトアジャスター
オ プ シ ョ ン	拡声器

◎ キャリヤ

メーカ名	FAUN GmbH
キャリヤ型式	ATF 130G-5
エンジン	OM502LA (ベンツ製) 水冷4サイクルV型8気筒直接噴射式 インタークーラ付ターボディーゼルエンジン
	総排気量 15.928 L
	最高出力 390 kW {530PS} / 1,800 min <sup>-1</sup> {rpm}
	最大トルク 2,400 N·m {245kgf·m} / 1,300 min <sup>-1</sup> {rpm}
変速機形式	フルオートマチック 前進12段、後退2段
駆動方式	10×6 10×8 — オフロード (デフロック機構付)
車軸形式 (全軸)	全浮動式
懸架方式 (全軸)	ハイドロニューマチックサスペンション サスペンションストローク $\begin{matrix} +160 \text{ mm} \\ -110 \text{ mm} \end{matrix}$
ステアリング形式	左ハンドル 全油圧式パワーステアリング 2系統式 非常用パワーステアリング
	モード ノーマル (前6輪+後4輪) クラブ (前6輪+後4輪)
ブレーキ	主ブレーキ 空気式全輪制動 2系統式 駐車ブレーキ 3・4・5軸 (6輪) 制動スプリング式 非常ブレーキ 駐車ブレーキと兼用 補助ブレーキ 流体式リターダ (変速機内蔵式) 排気ブレーキ
バッテリー	12V-170Ah × 2個 (24V)
燃料タンク容量	500 L
乗車定員	2人
タイヤ	445/95R25 177E ROAD (全輪)
ホイール	11.00-25 (全輪)
付属装置	カーエアコン AM・FMラジオ マッドガード 集中給油装置 仮眠用ベッド バックモニタ

## ◎ 走行時寸法

全	長	12,850 mm
全	幅	2,780 mm
全	高	4,020 mm
軸	距	2,560 mm+1,650 mm+2,000 mm+1,700mm
輪	距	2,310 mm

## ◎ 重 量 (公道走行状態)

車 両 総 重 量		38,100 kg (人員 2 名)
前 軸 重	1軸+2軸	18,580 kg
後 軸 重	3軸	1,550 kg
後 軸 重	4軸+5軸	17,970 kg

## ◎ 走行性能

最 高 速 度		85 km/h
登 坂 能 力	(tan $\theta$ )	0.7
最 小 回 転 半 径		9.31 m

- (注意) 1. 本機は、公道を走行する場合には、ブームを取外し、旋回体を後方向に向けた状態で走行しなければなりません。
2. 道路法による基本通行条件のC条件適合車です。

## 2. 定格総荷重表

### 2.1 ESPブーム定格総荷重表

1. 定格総荷重は、アウトリガを水平堅土上に設置したときの値で、太線より上側はクレーンの強度に基づき、下側は、クレーンの安定に基づいています。
2. 定格総荷重表の性能区分A～Tは、下表のとおりです。

カウンタ ウェイト アウトリガ 張出幅	40 t	28 t	25 t	15 t	6 t	0 t
7.5 m	A	B	C	D	E	K
6.2 m	F	G	H	I	J	K
5.0 m		L	M	N	O	P
4.1 m				Q	R	S
2.5 m						T

※同じ性能区分・ブーム長さでも、ブームの伸長状態によって定格総荷重が異なります。  
 ※S性能は51.7mブーム、T性能は25.8mブームまでとなります。

3. 定格総荷重は、つり具質量とフック質量（90 tフック：1,120kg、50 tフック：600kg、22 tフック：375kg、7.3 tフック：300kg）を含んだ値を示します。
4. 定格総荷重は、ブームのたわみを含んだ実際の作業半径に基づいています。
5. 各ブーム長さにおける標準フックとワイヤロープ標準巻掛本数は、ブームの各定格総荷重表中最下段に記載しています。ただし、この掛数以外で使用する場合は、ロープ1本当りの荷重は、主巻は6.5 t以下、補巻は7.3 t以下としてください。  
 ※シングルトップ使用時の巻掛本数は1（7.3 tフック使用）です。
6. シングルトップの定格総荷重は、ブームの定格総荷重からブームに取り付けられているフックの質量を差し引いた値とし、かつ限度は7.3 tです。
7. 定格総荷重表は、風による影響を含んでいません。瞬間最大風速が10m/s以上の風速では、クレーン作業を中止してください。

■A性能

6段ESPブーム

単位: t

性能プロック	1	1	9	10	1	9	10	2	1	10	11	2	1	10	11	2	1	11	2	3	1	2	3	1	5	3	4	1	6	7	1	7	1	1	8					
性能番号	1	1	26	28	2	27	29	12	3	30	32	13	4	31	33	14	5	34	15	17	6	16	18	7	21	19	20	8	22	23	9	24	10	11	25					
ブーム長さ(m)	※12.8		17.1				21.4				25.8				30.1				34.4				38.7				43.0				47.4				51.7		56.0		60.0	
作業半径(m)	※※																																							
2.7	130.0																																							
3.0	111.2	103.4	86.9	86.9	45.5	86.9	85.6	46.6	34.1																															
3.5	99.7	94.4	86.9	84.0	42.8	86.9	80.2	46.6	32.0	70.0	50.0	46.6	34.7																											
4.0	91.4	86.8	86.9	79.0	40.5	86.9	75.5	46.0	29.9	70.0	50.0	46.6	33.0																											
4.5	83.3	80.2	80.5	74.5	38.3	80.3	71.3	44.0	28.0	70.0	50.0	45.7	31.1	54.3	50.0	42.4	26.6																							
5.0	75.8	74.5	74.7	70.5	36.4	74.5	67.5	41.6	26.3	70.0	50.0	44.0	29.2	51.3	50.0	42.4	25.4	44.0	38.0	29.5	25.1																			
6.0	66.3	64.7	65.0	63.8	33.1	64.8	61.0	37.2	23.5	65.4	50.0	40.9	26.0	46.1	50.0	42.4	23.1	42.2	38.0	28.6	23.4	32.8	27.4	20.5																
7.0	58.8	56.6	56.9	57.4	30.4	56.7	55.7	33.6	21.2	57.3	46.6	37.3	23.3	41.8	49.3	39.6	20.6	38.4	38.0	26.8	21.9	32.8	26.9	20.5	27.1	23.1	20.7	19.0												
8.0	52.7	49.7	50.0	50.6	28.2	49.8	50.8	30.7	19.3	50.5	43.2	34.3	21.2	38.2	46.0	36.7	18.6	35.1	38.0	24.9	20.5	32.6	25.5	20.0	27.1	23.1	20.3	19.0	21.4	18.6	15.7									
9.0	47.7	43.9	44.2	44.8	26.2	44.0	44.9	28.2	17.7	44.7	40.2	31.7	19.4	35.2	43.1	34.1	16.9	32.4	35.8	23.3	19.1	30.3	24.3	18.5	27.1	23.1	19.4	18.5	21.4	18.6	15.7	16.6	14.3							
10.0	42.1	38.3	39.4	40.0	24.6	39.2	40.1	26.0	16.3	39.9	37.7	29.4	17.8	32.2	40.6	31.9	15.5	29.9	33.7	21.9	17.8	28.1	23.1	17.2	26.0	23.0	18.5	17.7	21.4	18.6	15.7	16.6	14.3	13.2						
11.0		35.4	35.9	23.2	35.1	36.1	24.2	15.1	35.8	35.4	27.5	16.5	29.5	36.7	30.0	14.3	27.8	31.8	20.6	16.5	26.2	21.9	16.0	24.7	22.1	17.7	16.7	21.4	18.6	15.7	16.6	14.3	13.2	10.6						
12.0		32.0	32.5	22.0	31.7	32.7	22.6	14.1	32.4	33.5	25.8	15.3	27.2	33.2	28.3	13.2	26.0	30.1	19.5	15.3	24.5	20.8	14.9	23.1	21.2	16.9	15.7	21.4	18.6	15.7	16.6	14.3	13.2	10.6						
14.0		26.5	27.1	20.2	26.2	27.2	20.0	12.4	26.9	28.2	22.9	13.4	23.3	27.7	25.4	11.5	22.5	27.2	17.5	13.3	21.6	18.8	13.2	20.4	19.6	15.5	14.0	19.2	16.7	14.5	16.4	14.3	13.2	10.6						
16.0					21.4	22.4	18.0	11.1	22.1	23.4	20.7	11.9	20.3	22.9	23.0	10.1	19.6	23.8	15.8	11.8	19.3	17.2	11.7	18.2	18.0	14.4	12.6	17.4	15.2	13.2	15.5	13.4	13.1	10.6						
18.0					17.6	18.6	16.4	10.1	18.2	19.5	18.8	10.7	17.8	19.0	20.3	9.0	17.2	19.9	14.3	10.6	17.1	15.8	10.6	16.4	16.7	13.2	11.4	15.4	13.9	12.0	14.4	12.5	12.4	10.5						
20.0									15.3	16.5	17.3	9.8	14.9	16.1	17.3	8.1	15.3	16.9	13.0	9.5	15.2	14.7	9.5	14.5	15.1	12.1	10.4	13.8	12.8	11.0	13.4	11.5	11.8	10.4						
22.0									13.0	14.2	15.1	9.0	12.6	13.7	14.9	7.3	13.3	14.5	11.9	8.7	13.6	13.5	8.6	13.0	13.5	11.1	9.6	12.4	11.7	10.2	12.0	10.7	11.1	9.6						
24.0													10.7	11.8	13.0	6.7	11.4	12.6	11.0	8.0	12.1	12.4	7.8	11.6	12.2	10.2	8.8	11.2	10.7	9.2	10.9	9.9	10.3	8.8						
26.0														9.2	10.3	11.5	6.1	9.8	11.0	10.3	7.3	10.5	11.6	7.1	10.5	11.1	9.4	8.1	10.2	9.8	8.4	9.9	9.3	9.7	8.0					
28.0																		8.5	9.7	9.6	6.8	9.2	10.3	6.6	9.3	9.8	8.7	7.5	9.3	9.0	7.7	9.0	8.6	8.9	7.3					
30.0																		7.5	8.6	9.1	6.4	8.1	9.1	6.0	8.1	8.6	8.1	6.9	8.4	8.3	7.1	8.3	7.9	8.1	6.7					
32.0																									7.1	8.1	5.6	7.2	7.7	6.5	7.4	7.7	6.6	7.6	7.4	7.5	6.2			
34.0																									6.3	7.3	5.2	6.3	6.8	7.1	6.0	6.5	7.2	6.1	6.8	6.8	6.9	5.7		
36.0																										5.6	6.1	6.7	5.6	5.8	6.5	5.7	6.1	6.4	6.4	5.3				
38.0																										5.0	5.4	6.2	5.3	5.1	5.8	5.3	5.4	6.0	5.7	4.9				
40.0																										4.4	4.9	5.6	5.0											
42.0																																								
44.0																																								
46.0																																								
48.0																																								
50.0																																								
52.0																																								
54.0																																								
56.0																																								
伸縮率(%)	31.9	32.7	34.4	34.5	30.4	31.9	33.3	27.8	30.0	32.1	32.3	32.2	26.5	29.9	30.7	26.6	26.5	28.8	29.5	25.1	27.1	27.4	20.5	26.6	23.1	20.7	19.0	21.4	18.6	15.7	16.6	14.3	13.2	10.6						
伸縮率(%)	0~82.7	0~82.7	0~82.7	0~82.7	0~82.7	0~82.7	0~82.7	0~82.7	0~82.7	0~82.7	0~82.7	0~82.7	0~82.7	0~82.7	0~82.7	0~82.7	0~82.7	0~82.7	0~82.7	0~82.7	0~82.7	0~82.7	0~82.7	0~82.7	0~82.7	0~82.7	0~82.7	0~82.7	0~82.7	0~82.7	0~82.7	0~82.7	0~82.7	0~82.7	0~82.7	0~82.7				
2段目ブーム	0	0	0	0	0	46	0	0	0	46	0	0	0	92	46	0	0	0	92	46	0	0	92	46	0	92	46	0	92	46	0	92	46	0	92	100				
3段目ブーム	0	0	46	0	0	46	46	0	0	46	46	0	0	46	46	46	0	46	46	46	0	46	46	0	92	46	46	46	46	46	46	46	46	46	46	46	100			
4段目ブーム	0	0	0	46	0	0	46	0	0	46	46	46	0	46	46	46	0	46	46	46	46	46	46	92	46	46	46	92	92	92	92	92	92	92	92	100				
5段目ブーム	0	0	0	0	0	0	0	46	0	46	46	46	0	46	46	46	0	46	46	46	46	46	92	46	46	92	46	92	92	92	92	92	92	92	92	100				
6段目ブーム	0	0	0	0	46	0	0	46	92	0	0	46	92	0	46	92	0	46	92	92	46	92	46	92	46	92	46	46	92	46	92	46	92	46	92	100				
標準フック	90t×2	90t	90t	50t	90t	90t	50t	50t	90t	90t	50t	50t	90t	90t	50t	50t	90t	90t	50t	50t	50t	50t	50t	50t	50t	50t	50t	50t	50t	50t	50t	50t	50t	50t	50t	50t				
フック質量	1120kg×2	1120kg	1120kg	600kg	1120kg	1120kg	600kg	600kg	1120kg	1120kg	600kg	600kg	1120kg	1120kg	600kg	600kg	1120kg	1120kg	600kg	600kg	600kg	600kg	600kg	600kg	600kg	600kg	600kg	600kg	600kg	600kg	600kg	600kg	600kg	600kg	600kg	600kg				
標準巻掛本数	24	13	13	7	13	13	7	5	11	8	7	5	8	8	6	4	7	6	5	4	5	4	3	4	4	4	3	3	3	3	3	3	3	3	3					

注) カウンタウェイト40t、アウトリガ張出幅7.5m ※印はアタッチメント付き、ジブ無しの値です。 ※※印は後方限定の値です。



■B性能

6段ESPフレーム

単位:t

性能フラット 性能番号	1	9	10	1	9	10	2	1	10	11	2	1	10	11	2	1	11	2	3	1	2	3	1	5	3	4	1	6	7	1	7	1	1	8				
フレーム長さ(m)	※12.8	17.1			21.4				25.8				30.1				34.4				38.7				43.0				47.4				51.7				56.0	60.0
作業半径(m)	2.7	3.0	3.5	4.0	4.5	5.0	6.0	7.0	8.0	9.0	10.0	11.0	12.0	14.0	16.0	18.0	20.0	22.0	24.0	26.0	28.0	30.0	32.0	34.0	36.0	38.0	40.0	42.0	44.0	46.0	48.0	50.0	52.0	54.0	56.0			

注) カウンタウェイト28t、アウトリガ張出幅7.5m ※印はアタッチメント付き、ジブ無しでの値です。

■性能

6段ESPフォーム

単位:t

性能プロップ 性能番号	1	9	10	1	9	10	2	1	10	11	2	1	10	11	2	1	11	2	3	1	2	3	1	5	3	4	1	6	7	1	7	1	1	8				
フォーム長さ(m)	※12.8	17.1			21.4				25.8				30.1				34.4				38.7				43.0				47.4				51.7				56.0	60.0
作業半径(m)	2.7	3.0	3.5	4.0	4.5	5.0	6.0	7.0	8.0	9.0	10.0	11.0	12.0	14.0	16.0	18.0	20.0	22.0	24.0	26.0	28.0	30.0	32.0	34.0	36.0	38.0	40.0	42.0	44.0	46.0	48.0	50.0	52.0	54.0	56.0			
伸長状態(伸縮割合%)	0	0	0	0	46	0	0	0	46	0	0	0	92	46	0	0	92	46	0	0	92	46	0	92	92	46	0	92	46	0	92	46	92	100				
2段目フォーム	0	46	0	0	46	46	0	0	46	46	0	0	46	46	46	0	46	46	46	0	46	46	0	92	46	46	46	92	92	92	92	92	92	100				
3段目フォーム	0	0	46	0	0	46	0	0	46	46	46	0	46	46	46	0	46	46	46	46	46	46	46	46	46	46	46	46	46	46	46	46	46	46	100			
4段目フォーム	0	0	0	0	0	0	46	0	0	46	46	46	0	46	46	92	46	46	46	92	46	46	92	46	46	92	46	92	92	92	92	92	92	92	100			
5段目フォーム	0	0	0	0	0	0	0	46	92	0	0	46	92	0	46	92	0	46	92	92	46	92	92	46	92	92	92	92	92	92	92	92	92	92	100			
6段目フォーム	0	0	0	46	0	0	46	92	0	0	46	92	0	46	92	0	46	92	92	46	92	92	46	92	92	92	92	92	92	92	92	92	92	92	100			
標準フック	90t×2	90t	90t	50t	90t	90t	50t	50t	90t	90t	50t	50t	90t	90t	50t	50t	90t	90t	50t	50t	90t	90t	50t	50t	90t	90t	50t	50t	90t	90t	50t	50t	90t	90t	50t			
フック質量	1120kg×2	1120kg	1120kg	600kg	1120kg	1120kg	600kg	600kg	1120kg	1120kg	600kg	600kg	1120kg	1120kg	600kg	600kg	1120kg	1120kg	600kg	600kg	1120kg	1120kg	600kg	600kg	1120kg	1120kg	600kg	600kg	1120kg	1120kg	600kg	600kg	1120kg	1120kg	600kg			
標準巻掛本数	24	13	13	7	13	13	7	5	11	8	7	5	8	8	6	4	7	6	5	4	5	4	3	4	3	4	3	3	3	3	3	3	3	3				

注) カウンタウエイト25t、アウトリガ張出幅7.5m ※印はアタッチメント付き、ジブ無しでの値です。



■E性能

6段ESPブーム

単位:t

性能プロック	1	9	10	1	9	10	2	1	10	11	2	1	10	11	2	1	11	2	3	1	2	3	1	5	3	4	1	6	7	1	7	1	1	8					
性能番号	1	26	28	2	27	29	12	3	30	32	13	4	31	33	14	5	34	15	17	6	16	18	7	21	19	20	8	22	23	9	24	10	11	25					
ブーム長さ(m)	※12.8		17.1			21.4				25.8				30.1				34.4				38.7			43.0				47.4			51.7		56.0		60.0			
作業半径(m)	2.7		3.0			3.5				4.0				4.5				5.0				5.5			6.0				6.5			7.0		7.5		8.0		8.5	
106.4																																							
100.4	86.9	86.9	45.5	86.9	85.6	46.6	34.1																																
90.7	86.9	84.0	42.8	86.9	80.2	46.6	32.0	70.0	50.0	46.6	34.7																												
81.7	82.1	79.0	40.5	81.9	75.5	46.0	29.9	70.0	50.0	46.6	33.0																												
73.6	74.0	74.5	38.3	73.7	71.3	44.0	28.0	70.0	50.0	45.7	31.1	54.3	50.0	42.4	26.6																								
66.7	67.1	67.7	36.4	66.8	67.5	41.6	26.3	67.6	50.0	44.0	29.2	51.3	50.0	42.4	25.4	44.0	38.0	29.5	25.1																				
55.6	56.0	56.6	33.1	55.7	56.8	37.2	23.5	56.5	50.0	40.9	26.0	46.1	50.0	42.4	23.1	42.2	38.0	28.6	23.4	32.8	27.4	20.5																	
43.2	43.8	44.7	30.4	43.4	45.0	33.6	21.2	44.6	46.6	37.3	23.3	41.8	46.0	39.6	20.6	38.4	38.0	26.8	21.9	32.8	26.9	20.5	27.1	23.1	20.7	19.0													
33.0	33.6	34.4	28.2	33.2	34.7	30.7	19.3	34.3	36.2	34.3	21.2	33.9	35.5	36.7	18.6	35.0	36.8	24.9	20.5	32.6	25.5	20.0	27.1	23.1	20.3	19.0	21.4	18.6	15.7										
26.3	26.7	27.5	26.2	26.4	27.7	28.2	17.7	27.4	29.1	30.4	19.4	27.0	28.5	30.3	16.9	28.0	29.7	23.3	19.1	29.1	24.3	18.5	27.1	23.1	19.4	18.5	21.4	18.6	15.7	16.6	14.3								
20.8	21.4	22.5	23.8	20.9	22.8	25.0	16.3	22.3	24.1	25.3	17.8	21.8	23.5	25.2	15.5	23.0	24.6	21.9	17.8	24.1	23.1	17.2	24.2	23.0	18.5	17.7	21.4	18.6	15.7	16.6	14.3	13.2							
16.1	17.1	18.8	15.7	17.5	20.4	15.1	16.9	19.2	20.9	16.5	16.5	18.5	20.8	14.3	17.8	20.0	20.6	16.5	19.2	21.2	16.0	19.4	20.4	17.7	16.7	19.9	18.6	15.7	16.6	14.3	13.2				10.6				
12.5	13.4	14.9	12.1	13.7	16.4	14.1	13.2	15.3	16.9	15.3	12.8	14.6	16.7	13.2	14.0	16.0	17.8	15.3	15.3	17.1	14.9	15.5	16.3	16.9	15.7	15.9	17.1	15.7	15.1	14.3	13.2				10.6				
7.9	8.7	9.9	7.5	8.9	11.2	11.4	8.5	10.3	11.6	12.5	8.0	9.7	11.5	11.5	9.1	10.8	12.4	13.2	10.2	11.8	13.2	10.4	11.1	12.4	13.1	10.8	11.8	12.7	10.3	11.4	10.8				10.6				
4.6	6.0	8.0	8.2	5.5	7.2	8.4	9.2	5.1	6.6	8.3	9.5	6.0	7.7	9.1	9.8	7.1	8.6	9.8	7.2	7.9	9.1	9.7	7.6	8.5	9.4	7.3	8.3	7.7	7.7										
2.8	4.0	5.9	6.0	3.5	5.0	6.2	7.0	3.1	4.5	6.1	7.2	4.0	5.5	6.8	7.5	5.0	6.3	7.5	5.1	5.7	6.8	7.4	5.4	6.3	7.1	5.2	6.2	5.7	4.2										
2.1	3.5	4.6	5.3	1.7	3.0	4.5	5.6	2.5	4.0	5.2	5.9	3.4	4.7	5.8	6.5	4.2	5.2	5.7	3.9	4.7	5.4	3.8	4.7	5.4	3.8	4.7	4.2	4.2											
1.1	2.4	3.5	4.1	1.1	2.4	3.5	4.1	1.9	3.3	4.4	1.4	2.8	4.0	4.6	2.3	3.5	4.6	2.4	3.0	3.9	4.5	2.7	3.5	4.2	2.6	3.5	3.0	3.0											
1.0	2.4	3.4		1.9	3.0	3.6	1.4	2.6	3.6	1.4	2.0	3.0	3.6	1.4	2.6	3.6	1.4	2.0	3.0	3.5	1.7	2.5	3.2	1.8	2.6	2.1	2.1												
1.7	2.2			1.7	2.2			1.7	2.2			1.7	2.2			1.7	2.2			1.7	2.2			1.7	2.2			1.7	2.2										
1.2	1.7			1.2	1.7			1.2	1.7			1.2	1.7			1.2	1.7			1.2	1.7			1.2	1.7			1.2	1.7										
1.1				1.1				1.1				1.1				1.1			1.1				1.1			1.1			1.1										
31.9	32.7	34.4	34.5	30.4	31.9	33.3	27.8	30.0	32.1	32.3	32.2	26.5	29.9	30.7	26.6	26.5	28.8	29.5	25.1	27.1	27.4	20.5	26.6	23.1	20.7	19.0	21.4	18.6	15.7	16.6	14.3	13.2			10.6				
0~82.7	0~82.7	0~82.7	0~82.7	0~82.7	0~82.7	0~82.7	0~82.7	0~82.7	0~82.7	0~82.7	0~82.7	12~82.7	22~82.7	0~82.7	0~82.7	24~82.7	23~82.7	0~82.7	0~82.7	28~82.7	0~82.7	0~82.7	38~82.7	31~82.7	10~82.7	13~82.7	43~82.7	35~82.7	23~82.7	48~82.7	37~82.7	48~82.7	53~82.7						
伸長状態(伸縮割合%)																																							
2段目ブーム	0	0	0	0	46	0	0	0	46	0	0	0	92	46	0	0	92	46	0	0	92	46	0	92	92	46	0	92	46	0	92	46	92	100					
3段目ブーム	0	46	0	0	46	46	0	0	46	46	0	0	46	46	46	0	46	46	46	0	46	46	0	92	46	46	46	92	92	92	92	92	92	92	100				
4段目ブーム	0	0	46	0	0	46	0	0	46	46	46	0	46	46	46	46	46	46	46	46	46	46	46	46	46	46	46	46	46	46	46	46	46	46	100				
5段目ブーム	0	0	0	0	0	46	0	0	46	46	46	0	46	46	92	46	46	46	92	46	46	92	46	46	92	46	92	92	92	92	92	92	92	92	100				
6段目ブーム	0	0	0	46	0	0	46	92	0	0	46	92	0	46	92	92	46	92	92	46	92	92	46	92	92	92	92	92	92	92	92	92	92	92	100				
標準フック	90t×2	90t	90t	50t	90t	90t	50t	90t	90t	50t	50t	90t	90t	50t	50t	90t	90t	50t	50t	50t	50t	50t	50t	50t	50t	50t	50t	50t	50t	50t	50t	50t	50t	50t	50t				
フック質量	1120kg×2	1120kg	1120kg	600kg	1120kg	1120kg	600kg	1120kg	1120kg	600kg	600kg	1120kg	1120kg	600kg	600kg	1120kg	1120kg	600kg	600kg	600kg	600kg	600kg	600kg	600kg	600kg	600kg	600kg	600kg	600kg	600kg	600kg	600kg	600kg	600kg	600kg				
標準巻掛本数	24	13	13	7	13	13	7	5	11	8	7	5	8	8	6	4	7	6	5	4	5	4	3	4	4	3	3	3	3	3	3	3	3	3					

注) カウンタウエイt6t、アウトリガ張出幅7.5m ※印はアタッチメント付き、ジブ無しでの値です。

■F性能

6段ESPブーム

単位:t

性能プロック 性能番号	1	9	10	1	9	10	2	1	10	11	2	1	10	11	2	1	11	2	3	1	2	3	1	5	3	4	1	6	7	1	7	1	1	8			
ブーム長さ(m)	1	26	28	2	27	29	12	3	30	32	13	4	31	33	14	5	34	15	17	6	16	18	7	21	19	20	8	22	23	9	24	10	11	25			
作業半径(m)	※12.8		17.1			21.4				25.8				30.1				34.4				38.7				43.0				47.4			51.7	60.0			
2.7	109.0																																				
3.0	102.3	86.9	86.9	45.5	86.9	85.6	46.6	34.1																													
3.5	92.5	86.9	84.0	42.8	86.9	80.2	46.6	32.0	70.0	50.0	46.6	34.7																									
4.0	84.3	84.6	79.0	40.5	84.4	75.5	46.0	29.9	70.0	50.0	46.6	33.0																									
4.5	77.2	77.5	74.5	38.3	77.3	71.3	44.0	28.0	70.0	50.0	45.7	31.1	54.3	50.0	42.4	26.6																					
5.0	71.0	71.4	70.5	36.4	71.1	67.5	41.6	26.3	70.0	50.0	44.0	29.2	51.3	50.0	42.4	25.4	44.0	38.0	29.5	25.1																	
6.0	60.9	61.3	61.8	33.1	61.0	61.0	37.2	23.5	61.7	50.0	40.9	26.0	46.1	50.0	42.4	23.1	42.2	38.0	28.6	23.4	32.8	27.4	20.5														
7.0	53.0	53.4	53.9	30.4	53.1	54.0	33.6	21.2	53.8	46.6	37.3	23.3	41.8	49.3	39.6	20.6	38.4	38.0	26.8	21.9	32.8	26.9	20.5	27.1	23.1	20.7	19.0										
8.0	46.5	46.8	47.4	28.2	46.6	47.5	30.7	19.3	47.3	43.2	34.3	21.2	38.2	46.0	36.7	18.6	35.1	38.0	24.9	20.5	32.6	25.5	20.0	27.1	23.1	20.3	19.0	21.4	18.6	15.7							
9.0	40.9	41.2	41.8	26.2	41.0	42.0	28.2	17.7	41.7	40.2	31.7	19.4	35.2	42.5	34.1	16.9	32.4	35.8	23.3	19.1	30.3	24.3	18.5	27.1	23.1	19.4	18.5	21.4	18.6	15.7	16.6	14.3					
10.0	36.4	36.6	37.2	24.6	36.4	37.4	26.0	16.3	37.1	37.7	29.4	17.8	32.2	37.9	31.9	15.5	29.9	33.7	21.9	17.8	28.1	23.1	17.2	26.0	23.0	18.5	17.7	21.4	18.6	15.7	16.6	14.3	13.2				
11.0		32.8	33.3	23.2	32.5	33.5	24.2	15.1	33.2	34.5	27.5	16.5	29.5	34.1	30.0	14.3	27.8	31.8	20.6	16.5	26.2	21.9	16.0	24.7	22.1	17.7	16.7	21.4	18.6	15.7	16.6	14.3	13.2	10.6			
12.0		29.5	30.1	22.0	29.3	30.3	22.6	14.1	30.0	31.3	25.8	15.3	27.2	30.8	28.3	13.2	26.0	30.1	19.5	15.3	24.5	20.8	14.9	23.1	21.2	16.9	15.7	20.9	18.1	15.7	16.6	14.3	13.2	10.6			
14.0		23.4	24.0	20.2	23.1	24.2	20.0	12.4	23.8	25.2	22.9	13.4	23.3	24.7	25.4	11.5	22.5	25.6	17.5	13.3	21.6	18.8	13.2	20.4	19.6	15.5	14.0	19.2	16.7	14.5	16.4	14.3	13.2	10.6			
16.0		18.4	19.4	18.0	18.4	19.4	18.0	11.1	19.1	20.4	20.7	11.9	18.7	19.9	21.3	10.1	19.5	20.8	15.8	11.8	19.3	17.2	11.7	18.2	18.0	14.4	12.6	17.4	15.2	13.2	15.5	13.4	13.1	10.6			
18.0					15.0	16.0	16.4	10.1	15.6	16.9	17.8	10.7	15.3	16.4	17.7	9.0	16.0	17.2	14.3	10.6	16.8	15.8	10.6	16.4	16.7	13.2	11.4	15.4	13.9	12.0	14.4	12.5	12.4	10.5			
20.0									13.0	14.2	15.1	9.8	12.6	13.8	15.0	8.1	13.3	14.5	13.0	9.5	14.1	14.7	9.5	14.2	14.7	12.1	10.4	13.8	12.8	11.0	13.4	11.5	11.8	10.4			
22.0									11.0	12.1	13.0	9.0	10.6	11.7	12.9	7.3	11.2	12.4	11.9	8.7	12.0	13.0	8.6	12.0	12.5	11.1	9.6	12.3	11.7	10.2	12.0	10.7	11.1	9.6			
24.0													8.9	10.0	11.1	6.7	9.5	10.7	11.0	8.0	10.2	11.3	7.8	10.3	10.8	10.2	8.8	10.6	10.7	9.2	10.8	9.9	10.3	8.8			
26.0													7.5	8.6	9.7	6.1	8.1	9.3	10.3	7.3	8.8	9.9	7.1	8.9	9.4	8.4	8.1	9.1	9.8	8.4	9.3	9.3	9.7	8.0			
28.0																	7.0	8.1	9.1	6.8	7.7	8.7	6.6	7.7	8.2	8.7	7.5	7.9	8.6	7.7	8.2	8.6	8.5	7.3			
30.0																	5.9	7.1	8.1	6.4	6.7	7.7	6.0	6.7	7.2	8.0	6.9	6.9	7.6	7.1	7.2	7.9	7.5	6.7			
32.0																				5.8	6.8	5.6	5.8	6.3	7.1	6.5	6.1	6.7	6.6	6.3	7.0	6.6	6.2				
34.0																				4.9	6.1	5.2	4.9	5.6	6.3	6.0	5.2	5.9	6.1	5.6	6.3	5.9	5.7				
36.0																								4.2	4.8	5.7	5.6	4.5	5.3	5.7	4.8	5.6	5.2	5.2			
38.0																								3.6	4.2	5.1	5.3	3.8	4.6	5.2	4.2	5.0	4.6	4.6			
40.0																								3.0	3.6	4.5	5.0	3.2	4.0	4.7	3.6	4.5	4.0	4.0			
42.0																																					
44.0																																					
46.0																																					
48.0																																					
50.0																																				1.9	
52.0																																				1.8	
54.0																																				1.6	
56.0																																				1.2	
58.0																																				1.0	
トンボ最大荷重	31.9	32.7	34.4	34.5	30.4	31.9	33.3	27.8	30.0	32.1	32.3	32.2	26.5	29.9	30.7	28.6	26.5	28.8	29.5	25.1	27.1	27.4	20.5	26.6	23.1	20.7	19.0	21.4	18.6	15.7	16.6	14.3	13.2	10.6			
ブーム部分の自重 (無吊り時)(t)	0~82.7	0~82.7	0~82.7	0~82.7	0~82.7	0~82.7	0~82.7	0~82.7	0~82.7	0~82.7	0~82.7	0~82.7	0~82.7	0~82.7	0~82.7	0~82.7	0~82.7	0~82.7	0~82.7	0~82.7	0~82.7	0~82.7	0~82.7	0~82.7	0~82.7	0~82.7	0~82.7	0~82.7	0~82.7	0~82.7	0~82.7	0~82.7	0~82.7	0~82.7			
伸長状態(伸縮割合%)																																					
2段目ブーム	0	0	0	0	46	0	0	0	46	0	0	0	92	46	0	0	92	46	0	0	92	46	0	92	92	46	0	92	46	0	92	46	92	100			
3段目ブーム	0	46	0	0	46	46	0	0	46	46	0	0	46	46	46	0	46	46	46	0	46	46	0	92	46	46	46	92	92	92	92	92	92	92	100		
4段目ブーム	0	0	46	0	0	46	0	0	46	46	46	0	46	46	46	0	46	46	46	46	46	46	0	92	46	46	46	92	92	92	92	92	92	92	100		
5段目ブーム	0	0	0	0	0	46	0	0	46	46	46	0	46	46	46	0	46	46	46	46	46	46	0	92	46	46	46	92	92	92	92	92	92	92	100		
6段目ブーム	0	0	0	46	0	0	46	92	0	0	46	92	0	46	92	0	46	92	92	46	92	92	46	92	92	46	46	92	92	92	92	92	92	100			
標準フック	90t×2	90t	90t	50t	90t	90t	50t	50t	90t	90t	50t	50t	90t	90t	50t	50t	90t	90t	50t	50t	50t	50t	50t	50t	50t	50t	50t	50t	50t	50t	50t	50t	50t	50t			
フック質量	1120kg×2	1120kg	1120kg	600kg	1120kg	1120kg	600kg	600kg	1120kg	1120kg	600kg	600kg	1120kg	1120kg	600kg	600kg	1120kg	1120kg	600kg	600kg	600kg	600kg	600kg	600kg	600kg	600kg	600kg	600kg	600kg	600kg	600kg	600kg	600kg	600kg			
標準巻掛本数	24	13	13	7	13	13	7	5	11	8	7	5	8	8	6	4	7	6	5	4	5	4	3	4	4	3	3	3	3	3	3	3	3				

注) カウンタウエイ40t、アウトリガ張出幅6.2m ※印はアタッチメント付き、ジブ無しの値です。

■G性能

6段ESPフーム

単位:t

性能フック 性能番号	1	9	10	1	9	10	2	1	10	11	2	1	10	11	2	1	11	2	3	1	2	3	1	5	3	4	1	6	7	1	7	1	1	1	8						
フーム長さ(m)	※12.8		17.1				21.4						25.8				30.1				34.4				38.7				43.0				47.4				51.7	56.0	60.0		
作業半径(m)	2.7		3.0				3.5						4.0				4.5				5.0				5.5				6.0				6.5				7.0	7.5	8.0	8.5	9.0
3.0	99.8	86.9	86.9	45.5	86.9	85.6	46.6	34.1																																	
3.5	90.1	86.9	84.0	42.8	86.9	80.2	46.6	32.0	70.0	50.0	46.6	34.7																													
4.0	81.8	82.2	79.0	40.5	82.0	75.5	46.0	29.9	70.0	50.0	46.6	33.0																													
4.5	74.8	75.2	74.5	38.3	74.9	71.3	44.0	28.0	70.0	50.0	45.7	31.1																													
5.0	68.7	69.1	69.6	36.4	68.8	67.5	41.6	26.3	69.5	50.0	44.0	29.2	51.3	50.0	42.4	25.4	44.0	38.0	29.5	25.1																					
6.0	58.5	58.9	59.4	33.1	58.6	59.6	37.2	23.5	59.3	50.0	40.9	26.0	46.1	50.0	42.4	23.1	42.2	38.0	28.6	23.4	32.8	27.4	20.5																		
7.0	50.0	50.4	50.9	30.4	50.1	51.1	33.6	21.2	50.8	46.6	37.3	23.3	41.8	49.3	39.6	20.6	38.4	38.0	26.8	21.9	32.8	26.9	20.5	27.1	23.1	20.7	19.0														
8.0	43.3	43.7	44.2	28.2	43.4	44.4	30.7	19.3	44.1	43.2	34.3	21.2	38.2	45.0	36.7	18.6	35.1	38.0	24.9	20.5	32.6	25.5	20.0	27.1	23.1	20.3	19.0	21.4	18.6	15.7											
9.0	38.0	38.3	38.8	26.2	38.0	39.0	28.2	17.7	38.7	40.1	31.7	19.4	35.2	39.6	34.1	16.9	32.4	35.8	23.3	19.1	30.3	24.3	18.5	27.1	23.1	19.4	18.5	21.4	18.6	15.7	16.6	14.3									
10.0	31.9	32.2	32.9	24.6	31.9	33.1	26.0	16.3	32.8	34.4	29.4	17.8	32.2	33.9	31.9	15.5	29.9	33.7	21.9	17.8	28.1	23.1	17.2	26.0	23.0	18.5	17.7	21.4	18.6	15.7	16.6	14.3	13.2								
11.0		27.2	27.9	23.2	26.9	28.1	24.2	15.1	27.7	29.3	27.5	16.5	27.4	28.8	30.0	14.3	27.8	29.8	20.6	16.5	26.2	21.9	16.0	24.7	22.1	17.7	16.7	21.4	18.6	15.7	16.6	14.3	13.2	10.6							
12.0		23.3	24.0	22.0	23.0	24.2	22.6	14.1	23.8	25.3	25.8	15.3	23.5	24.8	26.3	13.2	24.3	25.8	19.5	15.3	24.5	20.8	14.9	23.1	21.2	16.9	15.7	20.9	18.1	15.7	16.6	14.3	13.2	10.6							
14.0		17.8	18.4	19.3	17.5	18.5	20.0	12.4	18.2	19.6	20.6	13.4	17.9	19.1	20.5	11.5	18.6	20.0	17.5	13.3	19.5	18.8	13.2	19.6	19.6	15.5	14.0	19.2	16.7	14.5	16.4	14.3	13.2	10.6							
16.0		13.6	14.7	16.3	11.1	14.3	15.6	16.6	11.9	14.0	15.2	16.5	10.1	14.7	16.0	15.8	11.8	15.6	16.7	11.7	15.6	16.2	14.4	12.6	16.0	15.2	13.2	15.5	13.4	13.1	10.6										
18.0					10.9	11.9	13.4	10.1	11.5	12.7	13.7	10.7	11.1	12.3	13.6	9.0	11.9	13.1	14.2	10.6	12.7	13.8	10.6	12.7	13.3	13.2	11.4	13.0	13.8	12.0	13.1	12.5	12.4	10.5							
20.0									9.4	10.6	11.5	9.8	9.0	10.1	11.4	8.1	9.7	10.9	12.0	9.5	10.5	11.6	9.5	10.5	11.1	11.9	10.4	10.8	11.5	11.0	10.9	11.5	11.3	10.4							
22.0									7.7	8.9	9.8	9.0	7.3	8.4	9.6	7.3	8.0	9.2	10.2	8.7	8.7	9.8	8.6	8.8	9.3	10.1	9.6	9.0	9.7	10.2	9.2	10.0	9.5	9.5							
24.0													5.8	7.0	8.2	6.7	6.6	7.8	8.8	8.0	7.3	8.4	7.8	7.4	7.9	8.7	8.8	7.6	8.3	8.9	7.8	8.6	8.1	8.1							
26.0													4.6	5.9	7.1	6.1	5.3	6.6	7.6	7.3	6.2	7.2	7.1	6.2	6.7	7.5	8.0	6.5	7.1	7.7	6.7	7.4	7.0	7.0							
28.0																	4.3	5.7	6.6	6.8	5.1	6.2	6.6	5.2	5.7	6.5	7.0	5.5	6.1	6.7	5.7	6.4	6.0	6.0							
30.0																	3.4	4.8	5.8	6.3	4.2	5.4	6.0	4.2	4.9	5.7	6.1	4.5	5.3	5.9	4.8	5.6	5.2	5.2							
32.0																	3.4	4.7	5.5	3.4	4.1	5.0	5.4	3.7	4.5	5.1	4.0	4.9	4.4	4.4	4.4	4.4	4.4								
34.0																					2.7	4.0	4.8	2.7	3.4	4.3	4.8	3.0	3.8	4.5	3.4	4.2	3.7	3.7							
36.0																								2.1	2.7	3.7	4.2	2.4	3.2	3.9	2.8	3.6	3.1	3.1							
38.0																								1.6	2.2	3.1	3.7	1.8	2.7	3.3	2.2	3.1	2.6	2.6							
40.0																								1.2	1.8	2.7	3.2	1.4	2.2	2.9	1.7	2.6	2.1	2.1							
42.0																																									
44.0																																									
46.0																																									
48.0																																									
50.0																																									
52.0																																									
54.0																																									
56.0																																									
伸縮率(伸縮割合%)	31.9	32.7	34.4	34.5	30.4	31.9	33.3	27.8	30.0	32.1	32.3	32.2	26.5	29.9	30.7	26.6	26.5	28.8	29.5	25.1	27.1	27.4	20.5	26.6	23.1	20.7	19.0	21.4	18.6	15.7	16.6	14.3	13.2	10.6							
伸縮率(伸縮割合%)	0~82.7	0~82.7	0~82.7	0~82.7	0~82.7	0~82.7	0~82.7	0~82.7	0~82.7	0~82.7	0~82.7	0~82.7	0~82.7	0~82.7	0~82.7	0~82.7	0~82.7	0~82.7	0~82.7	0~82.7	0~82.7	0~82.7	0~82.7	0~82.7	0~82.7	0~82.7	0~82.7	0~82.7	0~82.7	0~82.7	0~82.7	0~82.7	0~82.7	0~82.7	0~82.7						
2段目フーム	0	0	0	0	46	0	0	0	46	0	0	0	92	46	0	0	92	46	0	0	92	46	0	92	92	46	0	92	46	0	92	46	92	100							
3段目フーム	0	46	0	0	46	46	0	0	46	46	0	0	46	46	46	0	46	46	46	0	46	46	0	92	46	46	46	92	92	92	92	92	92	92	100						
4段目フーム	0	0	46	0	0	46	0	0	46	46	46	0	46	46	46	0	46	46	46	46	46	46	46	92	46	46	46	92	92	92	92	92	92	92	100						
5段目フーム	0	0	0	0	0	0	46	0	0	46	46	46	0	46	46	92	46	46	46	92	46	46	92	46	46	92	92	92	92	92	92	92	92	100							
6段目フーム	0	0	0	46	0	0	46	92	0	0	46	92	0	0	46	92	0	46	92	92	46	92	92	46	92	92	92	92	92	92	92	92	92	100							
標準フック	90t×2	90t	90t	50t	90t	90t	50t	50t	90t	90t	50t	50t	90t	90t	50t	50t	90t	90t	50t	50t	50t	50t	50t	50t	50t	50t	50t	50t	50t	50t	50t	50t	50t	50t	50t						
フック質量	1120kg×2	1120kg	1120kg	600kg	1120kg	1120kg	600kg	600kg	1120kg	1120kg	600kg	600kg	1120kg	1120kg	600kg	600kg	1120kg	1120kg	600kg	600kg	600kg	600kg	600kg	600kg	600kg	600kg	600kg	600kg	600kg	600kg	600kg	600kg	600kg	600kg	600kg						
標準巻掛本数	24	13	13	7	13	13	7	5	11	8	7	5	8	8	6	4	7	6	5	4	5	4	3	4	3	4	3	3	3	3	3	3	3	3	3						

注) カウンタウエイト28t、アウトリガ張出幅6.2m ※印はアタッチメント付き、ジブ無しでの値です。

■H性能  
6段ESPブーム

性能ブロック	1	9	10	1	9	10	2	1	10	11	2	1	10	11	2	1	11	2	3	1	2	3	1	5	3	4	
性能番号	1	26	28	2	27	29	12	3	30	32	13	4	31	33	14	5	34	15	17	6	16	18	7	21	19	20	
ブーム長さ(m) 作業半径(m)	※12.8	17.1			21.4				25.8				30.1				34.4				38.7			43.0			
2.7	105.8																										
3.0	99.1	86.9	86.9	45.5	86.9	85.6	46.6	34.1																			
3.5	89.4	86.9	84.0	42.8	86.9	80.2	46.6	32.0	70.0	50.0	46.6	34.7															
4.0	81.2	81.5	79.0	40.5	81.3	75.5	46.0	29.9	70.0	50.0	46.6	33.0															
4.5	74.1	74.5	74.5	38.3	74.3	71.3	44.0	28.0	70.0	50.0	45.7	31.1	54.3	50.0	42.4	26.6											
5.0	68.1	68.4	68.9	36.4	68.2	67.5	41.6	26.3	68.8	50.0	44.0	29.2	51.3	50.0	42.4	25.4	44.0	38.0	29.5	25.1							
6.0	57.5	57.9	58.4	33.1	57.6	58.6	37.2	23.5	58.3	50.0	40.9	26.0	46.1	50.0	42.4	23.1	42.2	38.0	28.6	23.4	32.8	27.4	20.5				
7.0	49.0	49.4	50.0	30.4	49.2	50.2	33.6	21.2	49.9	46.6	37.3	23.3	41.8	49.3	39.6	20.6	38.4	38.0	26.8	21.9	32.8	26.9	20.5	27.1	23.1	20.7	
8.0	42.4	42.8	43.4	28.2	42.5	43.5	30.7	19.3	43.3	43.2	34.3	21.2	38.2	44.2	36.7	18.6	35.1	38.0	24.9	20.5	32.6	25.5	20.0	27.1	23.1	20.3	
9.0	35.8	36.3	37.0	26.2	35.9	37.2	28.2	17.7	36.9	38.6	31.7	19.4	35.2	38.0	34.1	16.9	32.4	35.8	23.3	19.1	30.3	24.3	18.5	27.1	23.1	19.4	
10.0	29.6	29.9	30.6	24.6	29.6	30.9	26.0	16.3	30.5	32.1	29.4	17.8	30.1	31.6	31.9	15.5	29.9	32.7	21.9	17.8	28.1	23.1	17.2	26.0	23.0	18.8	
11.0		25.2	25.9	23.2	24.9	26.1	24.2	15.1	25.8	27.3	27.5	16.5	25.4	26.8	28.4	14.3	26.3	27.8	20.6	16.5	26.2	21.9	16.0	24.7	22.1	17.7	
12.0		21.6	22.2	22.0	21.3	22.4	22.6	14.1	22.1	23.6	24.7	15.3	21.7	23.1	24.6	13.2	22.6	24.0	19.5	15.3	23.5	20.8	14.9	23.1	21.2	16.9	
14.0		16.3	16.9	17.9	16.0	17.1	18.9	12.4	16.8	18.1	19.2	13.4	16.4	17.7	19.1	11.5	17.2	18.6	17.5	13.3	18.1	18.8	13.2	18.2	18.8	15.5	
16.0					12.4	13.5	15.1	11.1	13.1	14.4	15.4	11.9	12.8	14.0	15.3	10.1	13.5	14.8	15.8	11.8	14.4	15.5	11.7	14.4	15.0	14.4	
18.0					9.8	10.8	12.4	10.1	10.5	11.7	12.6	10.7	10.1	11.3	12.5	9.0	10.8	12.1	13.2	10.6	11.6	12.8	10.6	11.7	12.2	13.1	
20.0									8.5	9.6	10.6	9.8	8.1	9.2	10.4	8.1	8.8	10.0	11.0	9.5	9.5	10.6	9.5	9.6	10.1	11.0	
22.0									6.9	8.0	8.9	9.0	6.4	7.6	8.8	7.3	7.1	8.3	9.4	8.7	7.9	9.0	8.6	8.0	8.5	9.3	
24.0													5.0	6.3	7.5	6.7	5.8	7.0	8.0	8.0	6.6	7.6	7.8	6.6	7.1	8.0	
26.0													3.8	5.2	6.4	6.1	4.6	5.9	6.9	7.3	5.5	6.5	7.1	5.5	6.0	6.8	
28.0																	3.6	5.0	6.0	6.5	4.4	5.6	6.4	4.5	5.1	5.9	
30.0																	2.7	4.1	5.2	5.7	3.5	4.8	5.6	3.6	4.2	5.1	
32.0																					2.8	4.1	4.9	2.8	3.5	4.4	
34.0																					2.2	3.4	4.3	2.2	2.8	3.7	
36.0																								1.6	2.2	3.2	
38.0																								1.1	1.7	2.6	
40.0																										1.3	2.2
42.0																											
44.0																											
46.0																											
48.0																											
50.0																											
52.0																											
54.0																											
56.0																											
ピン無最大荷重	31.9	32.7	34.4	34.5	30.4	31.9	33.3	27.8	30.0	32.1	32.3	32.2	26.5	29.9	30.7	26.6	26.5	28.8	29.5	25.1	27.1	27.4	20.5	26.6	23.1	20.7	
ブーム傾斜角の範囲 (無負荷時) (度)	0~82.7	0~82.7	0~82.7	0~82.7	0~82.7	0~82.7	0~82.7	0~82.7	0~82.7	0~82.7	0~82.7	0~82.7	0~82.7	0~82.7	0~82.7	0~82.7	0~82.7	0~82.7	0~82.7	0~82.7	0~82.7	0~82.7	0~82.7	0~82.7	0~82.7	0~82.7	
伸長状態(伸縮割合%)																											
2段目ブーム	0	0	0	0	46	0	0	0	46	0	0	0	92	46	0	0	92	46	0	0	92	46	0	92	92	46	
3段目ブーム	0	46	0	0	46	46	0	0	46	46	0	0	46	46	46	0	46	46	46	0	46	46	0	46	46	46	
4段目ブーム	0	0	46	0	0	46	0	0	46	46	46	0	46	46	46	0	46	46	46	46	46	46	46	92	46	46	
5段目ブーム	0	0	0	0	0	0	46	0	0	46	46	46	0	46	46	92	46	46	46	92	46	46	92	46	46	92	
6段目ブーム	0	0	0	46	0	0	46	92	0	0	46	92	0	0	46	92	0	46	92	92	46	92	92	46	92	92	
標準フック	90t×2	90t	90t	50t	90t	90t	50t	50t	90t	90t	50t	50t	90t	90t	50t	50t	90t	90t	50t	50t	50t	50t	50t	50t	50t	50t	
フック質量	1120kg×2	1120kg	1120kg	600kg	1120kg	1120kg	600kg	600kg	1120kg	1120kg	600kg	600kg	1120kg	1120kg	600kg	600kg	1120kg	1120kg	600kg	600kg	1120kg	1120kg	600kg	600kg	600kg	600kg	
標準巻掛本数	24	13	13	7	13	13	7	5	11	8	7	5	8	8	6	4	7	6	5	4	5	4	3	4	4	3	

注) カウンタウエイト25t、アウトリガ張出幅6.2m ※印はアタッチメント付き、ジブ無しでの値です。

■性能

6段ESPブーム

性能ブロック	1	9	10	1	9	10	2	1	10	11	2	1	10	11	2	1	11	2	3	1	2	3	1	5	3	4		
性能番号	1	26	28	2	27	29	12	3	30	32	13	4	31	33	14	5	34	15	17	6	16	18	7	21	19	20		
ブーム長さ(m)	※12.8		17.1			21.4				25.8				30.1				34.4				38.7			43.0			
作業半径 (m)	103.5																											
2.7																												
3.0	96.8	86.9	86.9	45.5	86.9	85.6	46.6	34.1																				
3.5	87.1	86.9	84.0	42.8	86.9	80.2	46.6	32.0	70.0	50.0	46.6	34.7																
4.0	78.9	79.3	79.0	40.5	79.0	75.5	46.0	29.9	70.0	50.0	46.6	33.0																
4.5	71.6	72.1	72.7	38.3	71.8	71.3	44.0	28.0	70.0	50.0	45.7	31.1	54.3	50.0	42.4	26.6												
5.0	64.9	65.3	65.9	36.4	65.0	66.1	41.6	26.3	65.8	50.0	44.0	29.2	51.3	50.0	42.4	25.4	44.0	38.0	29.5	25.1								
6.0	54.1	54.5	55.1	33.1	54.2	55.3	37.2	23.5	55.0	50.0	40.9	26.0	46.1	50.0	42.4	23.1	42.2	38.0	28.6	23.4	32.8	27.4	20.5					
7.0	45.2	45.8	46.7	30.4	45.4	47.0	33.6	21.2	46.6	46.6	37.3	23.3	41.8	47.7	39.6	20.6	38.4	38.0	26.8	21.9	32.8	26.9	20.5	27.1	23.1	20.7		
8.0	34.5	35.0	35.8	28.2	34.6	36.0	30.7	19.3	35.6	37.6	34.3	21.2	35.2	36.9	36.7	18.6	35.1	38.0	24.9	20.5	32.6	25.5	20.0	27.1	23.1	20.3		
9.0	27.4	27.8	28.5	26.2	27.4	28.8	28.2	17.7	28.4	30.2	31.5	19.4	28.0	29.6	31.4	16.9	29.0	30.7	23.3	19.1	30.2	24.3	18.5	27.1	23.1	19.4		
10.0	22.4	22.7	23.4	24.6	22.4	23.6	25.8	16.3	23.3	24.9	26.1	17.8	22.9	24.4	26.0	15.5	23.8	25.4	21.9	17.8	24.9	23.1	17.2	25.0	23.0	18.5		
11.0		18.9	19.6	20.7	18.6	19.8	21.8	15.1	19.4	21.0	22.2	16.5	19.1	20.5	22.1	14.3	20.0	21.5	20.6	16.5	21.0	21.9	16.0	21.1	21.7	17.7		
12.0		16.0	16.6	17.7	15.7	16.8	18.8	14.1	16.5	18.0	19.1	15.3	16.1	17.5	19.0	13.2	17.0	18.4	19.5	15.3	17.9	19.3	14.9	18.0	18.7	16.5		
14.0		11.8	12.4	13.3	11.4	12.5	14.3	12.4	12.2	13.6	14.6	13.4	11.9	13.1	14.5	11.5	12.6	14.0	15.2	13.3	13.5	14.8	13.2	13.6	14.2	15.2		
16.0					8.6	9.6	11.3	11.1	9.2	10.5	11.5	11.9	8.9	10.1	11.4	10.1	9.6	10.9	12.1	11.8	10.5	11.7	11.7	10.6	11.1	12.1		
18.0					6.4	7.5	9.0	9.1	7.1	8.3	9.3	9.9	6.8	7.9	9.2	9.0	7.5	8.7	9.8	10.4	8.3	9.4	10.3	8.3	8.9	9.8		
20.0									5.4	6.7	7.6	8.2	4.9	6.2	7.5	8.1	5.8	7.0	8.1	8.6	6.6	7.7	8.6	6.6	7.2	8.0		
22.0									4.0	5.4	6.3	6.8	3.5	4.9	6.1	7.0	4.3	5.7	6.7	7.2	5.2	6.3	7.2	5.3	5.8	6.7		
24.0													2.3	3.7	5.1	5.9	3.1	4.6	5.6	6.1	4.0	5.2	6.1	4.1	4.7	5.6		
26.0														1.4	2.7	4.2	5.0	2.1	3.6	4.7	5.2	3.0	4.3	5.2	3.1	3.7	4.7	
28.0																		1.3	2.8	4.0	4.5	2.2	3.5	4.4	2.2	2.9	3.9	
30.0																			2.1	3.3	3.8	1.5	2.7	3.7	1.5	2.1	3.1	
32.0																												
34.0																												
36.0																												
38.0																												
40.0																												
42.0																												
44.0																												
46.0																												
48.0																												
50.0																												
52.0																												
54.0																												
56.0																												
ピン無最大荷重	31.9	32.7	34.4	34.5	30.4	31.9	33.3	27.8	30.0	32.1	32.3	32.2	26.5	29.9	30.7	26.6	26.5	28.8	29.5	25.1	27.1	27.4	20.5	26.6	23.1	20.7		
ブーム傾斜角の範囲 (無負荷時) (度)	0~82.7	0~82.7	0~82.7	0~82.7	0~82.7	0~82.7	0~82.7	0~82.7	0~82.7	0~82.7	0~82.7	0~82.7	0~82.7	0~82.7	0~82.7	0~82.7	0~82.7	0~82.7	0~82.7	0~82.7	0~82.7	0~82.7	0~82.7	0~82.7	0~82.7	0~82.7		
伸長状態 (伸縮割合%)																												
2段目ブーム	0	0	0	0	46	0	0	0	46	0	0	0	92	46	0	0	92	46	0	0	92	46	0	92	92	46		
3段目ブーム	0	46	0	0	46	46	0	0	46	46	0	0	46	46	46	0	46	46	46	0	46	46	0	46	46	46		
4段目ブーム	0	0	46	0	0	46	0	0	46	46	46	0	46	46	46	0	46	46	46	46	46	46	46	46	46	46		
5段目ブーム	0	0	0	0	0	0	46	0	0	46	46	46	0	46	46	92	46	46	46	92	46	46	92	46	46	92		
6段目ブーム	0	0	0	46	0	0	46	92	0	0	46	92	0	0	46	92	0	46	92	92	46	92	92	46	92	92		
標準フック	90t×2	90t	90t	50t	90t	90t	50t	50t	90t	90t	50t	50t	90t	90t	50t	50t	90t	90t	50t	50t	50t	50t	50t	50t	50t	50t		
フック質量	1120kg×2	1120kg	1120kg	600kg	1120kg	1120kg	600kg	600kg	1120kg	1120kg	600kg	600kg	1120kg	1120kg	600kg	600kg	1120kg	1120kg	600kg	600kg	600kg	600kg	600kg	600kg	600kg	600kg		
標準巻掛本数	24	13	13	7	13	13	7	5	11	8	7	5	8	8	6	4	7	6	5	4	5	4	3	4	4	3		

注) カウンタウエイト15t、アウトリガ張出幅6.2m ※印はアタッチメント付き、ジブ無しでの値です。



■J性能

6段ESPブーム

性能ブロック	1	9	10	1	9	10	2	1	10	11	2	1	10	11	2	1	11	2	3	1	2	3	1	5	3	4					
性能番号	1	26	28	2	27	29	12	3	30	32	13	4	31	33	14	5	34	15	17	6	16	18	7	21	19	20					
ブーム長さ(m)	※12.8		17.1			21.4				25.8				30.1				34.4				38.7			43.0						
作業半径 (m)	101.2																														
2.7																															
3.0	94.5	86.9	86.9	45.5	86.9	85.6	46.6	34.1																							
3.5	84.8	85.2	84.0	42.8	85.0	80.2	46.6	32.0	70.0	50.0	46.6	34.7																			
4.0	75.8	76.3	76.8	40.5	76.0	75.5	46.0	29.9	70.0	50.0	46.6	33.0																			
4.5	67.9	68.4	69.0	38.3	68.1	69.2	44.0	28.0	68.9	50.0	45.7	31.1	54.3	50.0	42.4	26.6															
5.0	61.3	61.8	62.4	36.4	61.5	62.6	41.6	26.3	62.3	50.0	44.0	29.2	51.3	50.0	42.4	25.4	44.0	38.0	29.5	25.1											
6.0	48.1	48.9	50.0	33.1	48.4	50.4	37.2	23.5	49.8	50.0	40.9	26.0	46.1	50.0	42.4	23.1	42.2	38.0	28.6	23.4	32.8	27.4	20.5								
7.0	33.9	34.5	35.4	30.4	34.1	35.7	33.6	21.2	35.3	37.4	37.3	23.3	34.8	36.7	38.9	20.6	36.0	38.0	26.8	21.9	32.8	26.9	20.5	27.1	23.1	20.7					
8.0	25.4	25.9	26.7	28.2	25.6	27.0	29.6	19.3	26.6	28.5	30.0	21.2	26.2	27.9	29.8	18.6	27.3	29.2	24.9	20.5	28.5	25.5	20.0	27.1	23.1	20.3					
9.0	19.9	20.3	21.0	22.4	19.9	21.3	23.6	17.7	20.9	22.7	24.0	19.4	20.5	22.1	23.9	16.9	21.5	23.2	23.3	19.1	22.7	24.2	18.5	22.8	23.1	19.4					
10.0	16.0	16.3	17.0	18.2	16.0	17.2	19.4	16.3	16.9	18.5	19.7	17.8	16.5	18.0	19.6	15.5	17.4	19.0	20.4	17.8	18.5	19.9	17.2	18.6	19.3	18.5					
11.0		13.3	14.0	15.1	13.0	14.2	16.2	15.1	13.9	15.4	16.6	16.5	13.5	14.9	16.5	14.3	14.4	15.9	17.2	16.5	15.4	16.8	16.0	15.5	16.1	17.2					
12.0		11.0	11.6	12.7	10.7	11.9	13.8	13.9	11.5	13.0	14.1	14.8	11.2	12.5	14.0	13.2	12.0	13.5	14.7	15.3	13.0	14.3	14.9	13.1	13.7	14.7					
14.0		7.7	8.3	9.2	7.4	8.5	10.2	10.3	8.1	9.5	10.5	11.2	7.8	9.0	10.4	11.5	8.6	9.9	11.1	11.7	9.5	10.7	11.7	9.6	10.2	11.1					
16.0					4.6	6.0	7.8	7.9	5.5	7.1	8.1	8.7	5.1	6.6	8.0	9.0	6.0	7.5	8.7	9.2	7.1	8.2	9.2	7.1	7.7	8.6					
18.0					2.8	4.0	5.9	6.0	3.5	5.0	6.2	6.9	3.1	4.5	6.1	7.2	4.0	5.5	6.8	7.4	5.0	6.3	7.3	5.1	5.7	6.8					
20.0									2.1	3.5	4.6	5.3	1.7	3.0	4.5	5.6	2.5	4.0	5.2	5.9	3.4	4.7	5.8	3.5	4.2	5.2					
22.0									1.1	2.4	3.5	4.1				1.9	3.3	4.4	1.4	2.8	4.0	4.6	2.3	3.5	4.6	2.4	3.9				
24.0															1.0	2.4	3.4		1.9	3.0	3.6	1.4	2.6	3.6	1.4	2.0	3.0				
26.0																	1.7	2.6		1.1	2.3	2.8		1.8	2.8		1.3	2.2			
28.0																				1.7	2.2			1.2	2.1		1.6				
30.0																				1.2	1.7						1.0				
32.0																															
34.0																															
36.0																															
38.0																															
40.0																															
42.0																															
44.0																															
46.0																															
48.0																															
50.0																															
52.0																															
54.0																															
56.0																															
ピン無最大荷重	31.9	32.7	34.4	34.5	30.4	31.9	33.3	27.8	30.0	32.1	32.3	32.2	26.5	29.9	30.7	26.6	26.5	28.8	29.5	25.1	27.1	27.4	20.5	26.6	23.1	20.7					
ブーム傾斜角の範囲 (無負荷時) (度)	0~82.7	0~82.7	0~82.7	0~82.7	0~82.7	0~82.7	0~82.7	0~82.7	0~82.7	0~82.7	0~82.7	0~82.7	33~82.7	13~82.7	0~82.7	0~82.7	38~82.7	21~82.7	0~82.7	0~82.7	41~82.7	25~82.7	0~82.7	48~82.7	43~82.7	32~82.7					
伸長状態 (伸縮割合%)																															
2段目ブーム	0	0	0	0	46	0	0	0	46	0	0	0	92	46	0	0	92	46	0	0	92	46	0	92	92	46	92	92	46		
3段目ブーム	0	46	0	0	46	46	0	0	46	46	0	0	46	46	46	0	46	46	46	0	46	46	0	46	46	46	46	46	46		
4段目ブーム	0	0	46	0	0	46	0	0	46	46	46	46	0	46	46	46	0	46	46	46	46	46	46	46	46	46	46	46	46		
5段目ブーム	0	0	0	0	0	0	46	0	0	46	46	46	0	46	46	46	92	46	46	46	92	46	46	92	46	46	46	46			
6段目ブーム	0	0	0	46	0	0	46	92	0	0	46	92	0	0	46	92	0	46	92	92	46	92	92	46	92	92	46	92	92		
標準フック	90t×2	90t	90t	50t	90t	90t	50t	50t	90t	90t	50t	50t	90t	90t	50t	50t	90t	90t	50t	50t	50t	50t	50t	50t	50t	50t	50t	50t	50t		
フック質量	1120kg×2	1120kg	1120kg	600kg	1120kg	1120kg	600kg	600kg	1120kg	1120kg	600kg	600kg	1120kg	1120kg	600kg	600kg	1120kg	1120kg	600kg	600kg	600kg	600kg	600kg	600kg	600kg	600kg	600kg	600kg	600kg		
標準巻掛本数	24	13	13	7	13	13	7	5	11	8	7	5	8	8	6	4	7	6	5	4	5	4	3	4	4	4	4	3			

注) カウンタウエイト6t、アウトリガ張出幅6.2m ※印はアタッチメント付き、ジブ無しでの値です。

■K性能

6段ESPブーム

性能ブロック	1	9	10	1	9	10	2	1	10	11	2	1	10	11	2	1	11	2	3	1	2	3	1	5	3	4		
性能番号	1	26	28	2	27	29	12	3	30	32	13	4	31	33	14	5	34	15	17	6	16	18	7	21	19	20		
ブーム長さ(m) 作業半径(m)	※12.8	17.1			21.4				25.8				30.1				34.4				38.7			43.0				
2.7	99.5																											
3.0	92.8	86.9	86.9	45.5	86.9	85.6	46.6	34.1																				
3.5	82.3	82.8	83.3	42.8	82.5	80.2	46.6	32.0	70.0	50.0	46.6	34.7																
4.0	73.0	73.5	74.0	40.5	73.2	74.3	46.0	29.9	70.0	50.0	46.6	33.0																
4.5	65.2	65.7	66.3	38.3	65.4	66.5	44.0	28.0	66.2	50.0	45.7	31.1	54.3	50.0	42.4	26.6												
5.0	58.7	59.1	59.7	36.4	58.9	60.0	41.6	26.3	59.7	50.0	44.0	29.2	51.3	50.0	42.4	25.4	44.0	38.0	29.5	25.1								
6.0	37.7	38.5	39.5	33.1	38.0	39.9	37.2	23.5	39.4	42.0	40.9	26.0	38.9	41.1	42.4	23.1	40.3	38.0	28.6	23.4	32.8	27.4	20.5					
7.0	26.1	26.7	27.6	29.2	26.3	27.9	30.8	21.2	27.5	29.6	31.2	23.3	27.0	28.9	31.1	20.6	28.2	30.3	26.8	21.9	29.6	26.9	20.5	27.1	23.1	20.7		
8.0	19.2	19.7	20.5	22.0	19.4	20.9	23.4	19.3	20.5	22.3	23.8	21.2	20.0	21.7	23.7	18.6	21.1	23.0	24.6	20.5	22.3	24.0	20.0	22.5	23.1	20.3		
9.0	14.7	15.1	15.9	17.2	14.8	16.2	18.4	17.7	15.8	17.5	18.8	19.4	15.4	17.0	18.7	16.9	16.4	18.1	19.6	19.1	17.5	19.1	18.5	17.6	18.4	19.4		
10.0	11.3	11.8	12.6	13.8	11.4	12.8	15.0	15.1	12.5	14.1	15.3	16.1	12.1	13.6	15.2	15.5	13.0	14.6	16.0	16.8	14.1	15.5	16.7	14.2	14.9	16.0		
11.0		8.3	9.3	11.0	7.9	9.7	12.4	12.5	9.2	11.4	12.7	13.5	8.7	10.7	12.6	13.8	10.0	12.1	13.4	14.1	11.4	12.9	14.0	11.6	12.3	13.4		
12.0		5.9	6.8	8.3	5.5	7.1	9.8	10.0	6.6	8.7	10.3	11.3	6.2	8.0	10.1	11.7	7.4	9.4	11.2	12.0	8.7	10.5	11.9	8.9	9.7	11.1		
14.0		2.8	3.6	4.9	2.4	3.9	6.2	6.3	3.4	5.2	6.6	7.5	3.0	4.6	6.5	7.8	4.0	5.8	7.4	8.2	5.2	6.8	8.1	5.3	6.1	7.3		
16.0						1.9	4.0	4.1	1.4	3.1	4.3	5.1	1.0	2.5	4.2	5.4	2.0	3.6	5.0	5.7	3.0	4.5	5.7	3.1	3.8	5.0		
18.0							2.5	2.5		1.6	2.8	3.5		1.1	2.6	3.8		2.1	3.4	4.1	1.5	2.9	4.0	1.6	2.3	3.4		
20.0										1.7	2.4				1.5	2.6		1.0	2.3	2.9		1.8	2.9		1.2	2.2		
22.0												1.5				1.7			1.4	2.0			1.9			1.3		
24.0																1.1				1.3			1.2					
26.0																												
28.0																												
30.0																												
32.0																												
34.0																												
36.0																												
38.0																												
40.0																												
42.0																												
44.0																												
46.0																												
48.0																												
50.0																												
52.0																												
54.0																												
56.0																												
ピン無最大荷重 ブーム稼働時の範囲 (無負荷時) (度)	31.9	32.7	34.4	34.5	30.4	31.9	33.3	27.8	30.0	32.1	32.3	32.2	26.5	29.9	30.7	26.6	26.5	28.8	29.5	25.1	27.1	27.4	20.5	26.6	23.1	20.7		
	0~82.7	0~82.7	0~82.7	0~82.7	13~82.7	21~82.7	0~82.7	0~82.7	30~82.7	22~82.7	21~82.7	0~82.7	46~82.7	36~82.7	16~82.7	22~82.7	50~82.7	39~82.7	19~82.7	22~82.7	52~82.7	41~82.7	24~82.7	59~82.7	53~82.7	45~82.7		
	伸長状態(伸縮割合%)																											
2段目ブーム	0	0	0	0	46	0	0	0	46	0	0	0	92	46	0	0	92	46	0	0	92	46	0	92	92	46		
3段目ブーム	0	46	0	0	46	46	0	0	46	46	0	0	46	46	46	0	46	46	46	0	46	46	0	46	46	46		
4段目ブーム	0	0	46	0	0	46	0	0	46	46	46	0	46	46	46	0	46	46	46	46	46	46	46	46	46	46		
5段目ブーム	0	0	0	0	0	0	46	0	0	46	46	46	0	46	46	92	46	46	46	92	46	46	92	46	46	92		
6段目ブーム	0	0	0	46	0	0	46	92	0	0	46	92	0	0	46	92	0	46	92	92	46	92	92	46	92	92		
標準フック	90t×2	90t	90t	50t	90t	90t	50t	50t	90t	90t	50t	50t	90t	90t	50t	50t	90t	90t	50t	50t	50t	50t	50t	50t	50t	50t		
フック質量	1120kg×2	1120kg	1120kg	600kg	1120kg	1120kg	600kg	600kg	1120kg	1120kg	600kg	600kg	1120kg	1120kg	600kg	600kg	1120kg	1120kg	600kg	600kg	600kg	600kg	600kg	600kg	600kg	600kg		
標準巻掛本数	24	13	13	7	13	13	7	5	11	8	7	5	8	8	6	4	7	6	5	4	5	4	3	4	4	3		

注) カウンタウエイト0t、アウトリガ張出幅7.5mまたは、カウンタウエイト0t、アウトリガ張出幅6.2m ※印はアタッチメント付き、ジブ無しでの値です。

■L性能

6段ESPブーム

性能ブロック	1	9	10	1	9	10	2	1	10	11	2	1	10	11	2	1	11	2	3	1	2	3	1	5	3	4		
性能番号	1	26	28	2	27	29	12	3	30	32	13	4	31	33	14	5	34	15	17	6	16	18	7	21	19	20		
ブーム長さ(m)	※12.8		17.1			21.4				25.8				30.1				34.4				38.7			43.0			
作業半径(m)	101.1																											
2.7																												
3.0	94.3	86.9	86.9	45.5	86.9	85.6	46.6	34.1																				
3.5	84.6	85.0	84.0	42.8	84.7	80.2	46.6	32.0	70.0	50.0	46.6	34.7																
4.0	76.4	76.8	77.3	40.5	76.6	75.5	46.0	29.9	70.0	50.0	46.6	33.0																
4.5	69.5	69.9	70.4	38.3	69.6	70.6	44.0	28.0	70.0	50.0	45.7	31.1	54.3	50.0	42.4	26.6												
5.0	63.6	63.9	64.5	36.4	63.7	64.6	41.6	26.3	64.4	50.0	44.0	29.2	51.3	50.0	42.4	25.4	44.0	38.0	29.5	25.1								
6.0	53.6	54.1	54.7	33.1	53.8	54.8	37.2	23.5	54.6	50.0	40.9	26.0	46.1	50.0	42.4	23.1	42.2	38.0	28.6	23.4	32.8	27.4	20.5					
7.0	45.4	45.9	46.6	30.4	45.6	46.7	33.6	21.2	46.5	46.6	37.3	23.3	41.8	47.4	39.6	20.6	38.4	38.0	26.8	21.9	32.8	26.9	20.5	27.1	23.1	20.7		
8.0	35.8	36.3	37.0	28.2	35.9	37.2	30.7	19.3	36.8	38.6	34.3	21.2	36.5	38.0	36.7	18.6	35.1	38.0	24.9	20.5	32.6	25.5	20.0	27.1	23.1	20.3		
9.0	29.2	29.5	30.2	26.2	29.2	30.4	28.2	17.7	30.1	31.7	31.7	19.4	29.8	31.2	32.8	16.9	30.6	32.2	23.3	19.1	30.3	24.3	18.5	27.1	23.1	19.4		
10.0	24.3	24.6	25.3	24.6	24.3	25.5	26.0	16.3	25.2	26.7	27.8	17.8	24.8	26.2	27.7	15.5	25.7	27.2	21.9	17.8	26.7	23.1	17.2	26.0	23.0	18.5		
11.0		20.9	21.5	22.6	20.6	21.7	23.6	15.1	21.4	22.8	23.9	16.5	21.0	22.3	23.8	14.3	21.9	23.3	20.6	16.5	22.8	21.9	16.0	22.9	22.1	17.7		
12.0		17.9	18.5	19.5	17.6	18.7	20.5	14.1	18.4	19.8	20.8	15.3	18.1	19.3	20.7	13.2	18.8	20.2	19.5	15.3	19.8	20.8	14.9	19.8	20.4	16.9		
14.0		13.6	14.2	15.1	13.3	14.3	16.0	12.4	14.0	15.3	16.3	13.4	13.7	14.9	16.2	11.5	14.4	15.7	16.8	13.3	15.3	16.4	13.2	15.3	15.9	15.5		
16.0					10.3	11.2	12.8	11.1	10.9	12.2	13.1	11.9	10.6	11.7	13.0	10.1	11.3	12.5	13.6	11.8	12.1	13.2	11.7	12.2	12.7	13.6		
18.0					8.0	9.0	10.5	10.1	8.6	9.8	10.7	10.7	8.3	9.4	10.6	9.0	9.0	10.2	11.2	10.6	9.8	10.9	10.6	9.8	10.4	11.2		
20.0									6.9	8.1	8.9	9.5	6.5	7.6	8.8	8.1	7.2	8.4	9.4	9.5	8.0	9.0	9.5	8.0	8.5	9.4		
22.0									5.4	6.7	7.5	8.1	4.9	6.2	7.4	7.3	5.7	7.0	8.0	8.5	6.5	7.6	8.4	6.6	7.1	7.9		
24.0													3.6	5.0	6.2	6.7	4.4	5.8	6.8	7.3	5.3	6.4	7.2	5.4	5.9	6.7		
26.0													2.6	3.9	5.3	6.1	3.4	4.8	5.8	6.3	4.2	5.4	6.2	4.3	4.9	5.7		
28.0																	2.5	3.9	5.0	5.5	3.3	4.6	5.4	3.4	4.0	4.9		
30.0																	1.7	3.1	4.3	4.8	2.5	3.8	4.7	2.6	3.2	4.2		
32.0																					1.9	3.1	4.1	1.9	2.5	3.5		
34.0																					1.3	2.5	3.5	1.3	1.9	2.9		
36.0																									1.4	2.3		
38.0																									1.0	1.5		
40.0																										1.5		
42.0																												
44.0																												
46.0																												
48.0																												
50.0																												
52.0																												
54.0																												
56.0																												
ピン無最大荷重	31.9	32.7	34.4	34.5	30.4	31.9	33.3	27.8	30.0	32.1	32.3	32.2	26.5	29.9	30.7	26.6	26.5	28.8	29.5	25.1	27.1	27.4	20.5	26.6	23.1	20.7		
ブーム稼働時の範囲(無負荷時)(度)	0~82.7	0~82.7	0~82.7	0~82.7	0~82.7	0~82.7	0~82.7	0~82.7	0~82.7	0~82.7	0~82.7	0~82.7	0~82.7	0~82.7	0~82.7	0~82.7	0~82.7	0~82.7	0~82.7	0~82.7	0~82.7	0~82.7	0~82.7	0~82.7	17~82.7	14~82.7	0~82.7	
伸長状態(伸縮割合%)																												
2段目ブーム	0	0	0	0	46	0	0	0	46	0	0	0	92	46	0	0	92	46	0	0	92	46	0	92	92	46	46	
3段目ブーム	0	46	0	0	46	46	0	0	46	46	0	0	46	46	46	0	46	46	46	0	46	46	0	46	46	46	46	
4段目ブーム	0	0	46	0	0	46	0	0	46	46	46	46	0	46	46	46	0	46	46	46	46	46	46	92	46	46	46	
5段目ブーム	0	0	0	0	0	0	46	0	0	46	46	46	0	46	46	92	46	46	46	92	46	46	92	46	46	46	92	
6段目ブーム	0	0	0	46	0	0	46	92	0	0	46	92	0	0	46	92	0	46	92	92	46	92	92	46	92	92	92	
標準フック	90t×2	90t	90t	50t	90t	90t	50t	50t	90t	90t	50t	50t	90t	90t	50t	50t	90t	90t	50t	50t	50t	50t	50t	50t	50t	50t	50t	
フック質量	1120kg×2	1120kg	1120kg	600kg	1120kg	1120kg	600kg	600kg	1120kg	1120kg	600kg	600kg	1120kg	1120kg	600kg	600kg	1120kg	1120kg	600kg	600kg	600kg	600kg	600kg	600kg	600kg	600kg	600kg	
標準巻掛本数	24	13	13	7	13	13	7	5	11	8	7	5	8	8	6	4	7	6	5	4	5	4	3	4	4	3		

注) カウンタウエイト28t、アウトリガ張出幅5.0m ※印はアタッチメント付き、ジブ無しでの値です。

■M性能

6段ESPブーム

性能ブロック	1	9	10	1	9	10	2	1	10	11	2	1	10	11	2	1	11	2	3	1	2	3	1	5	3	4		
性能番号	1	26	28	2	27	29	12	3	30	32	13	4	31	33	14	5	34	15	17	6	16	18	7	21	19	20		
ブーム長さ(m) 作業半径 (m)	※12.8	17.1			21.4				25.8				30.1				34.4				38.7			43.0				
2.7	100.1																											
3.0	93.4	86.9	86.9	45.5	86.9	85.6	46.6	34.1																				
3.5	83.7	84.1	84.0	42.8	83.8	80.2	46.6	32.0	70.0	50.0	46.6	34.7																
4.0	75.6	76.0	76.5	40.5	75.7	75.5	46.0	29.9	70.0	50.0	46.6	33.0																
4.5	68.7	69.1	69.6	38.3	68.8	69.8	44.0	28.0	69.5	50.0	45.7	31.1	54.3	50.0	42.4	26.6												
5.0	62.8	63.2	63.7	36.4	62.9	63.8	41.6	26.3	63.6	50.0	44.0	29.2	51.3	50.0	42.4	25.4	44.0	38.0	29.5	25.1								
6.0	52.6	53.0	53.6	33.1	52.7	53.7	37.2	23.5	53.5	50.0	40.9	26.0	46.1	50.0	42.4	23.1	42.2	38.0	28.6	23.4	32.8	27.4	20.5					
7.0	42.3	42.8	43.6	30.4	42.4	43.9	33.6	21.2	43.5	45.4	37.3	23.3	41.8	44.7	39.6	20.6	38.4	38.0	26.8	21.9	32.8	26.9	20.5	27.1	23.1	20.7		
8.0	33.2	33.7	34.4	28.2	33.3	34.6	30.7	19.3	34.3	36.0	34.3	21.2	33.9	35.4	36.7	18.6	34.9	36.6	24.9	20.5	32.6	25.5	20.0	27.1	23.1	20.3		
9.0	27.0	27.4	28.0	26.2	27.0	28.3	28.2	17.7	27.9	29.5	30.7	19.4	27.6	29.0	30.6	16.9	28.5	30.0	23.3	19.1	29.5	24.3	18.5	27.1	23.1	19.4		
10.0	22.5	22.7	23.4	24.5	22.4	23.6	25.6	16.3	23.3	24.8	25.9	17.8	22.9	24.3	25.8	15.5	23.8	25.3	21.9	17.8	24.8	23.1	17.2	24.9	23.0	18.5		
11.0		19.2	19.8	20.9	18.9	20.0	21.9	15.1	19.7	21.2	22.2	16.5	19.4	20.7	22.1	14.3	20.2	21.6	20.6	16.5	21.1	21.9	16.0	21.2	21.8	17.7		
12.0		16.4	17.0	18.1	16.1	17.2	19.0	14.1	16.9	18.3	19.3	15.3	16.6	17.8	19.2	13.2	17.4	18.7	19.5	15.3	18.3	19.5	14.9	18.4	19.0	16.9		
14.0		12.4	12.9	13.8	12.1	13.1	14.8	12.4	12.8	14.1	15.1	13.4	12.4	13.6	15.0	11.5	13.2	14.5	15.6	13.3	14.0	15.2	13.2	14.1	14.7	15.5		
16.0					9.2	10.2	11.8	11.1	9.9	11.1	12.1	11.9	9.5	10.7	12.0	10.1	10.2	11.5	12.6	11.8	11.1	12.2	11.7	11.1	11.7	12.6		
18.0					7.1	8.1	9.6	9.6	7.7	8.9	9.8	10.4	7.4	8.5	9.7	9.0	8.1	9.3	10.3	10.6	8.8	9.9	10.6	8.9	9.4	10.3		
20.0									6.0	7.2	8.1	8.7	5.6	6.8	8.0	8.1	6.4	7.6	8.6	9.1	7.2	8.2	9.1	7.2	7.7	8.6		
22.0									4.6	5.9	6.8	7.3	4.1	5.5	6.7	7.3	4.9	6.2	7.2	7.7	5.8	6.8	7.7	5.9	6.4	7.2		
24.0													2.9	4.3	5.6	6.4	3.7	5.1	6.1	6.6	4.6	5.7	6.6	4.6	5.3	6.1		
26.0													1.9	3.3	4.7	5.5	2.7	4.1	5.2	5.7	3.6	4.8	5.6	3.6	4.2	5.1		
28.0																	1.9	3.3	4.4	4.9	2.7	4.0	4.8	2.7	3.4	4.3		
30.0																	1.2	2.5	3.7	4.3	2.0	3.2	4.2	2.0	2.6	3.6		
32.0																												
34.0																												
36.0																												
38.0																												
40.0																												
42.0																												
44.0																												
46.0																												
48.0																												
50.0																												
52.0																												
54.0																												
56.0																												
ピン無最大荷重 ブーム際荷重の範囲 (無負荷時) (度)	31.9	32.7	34.4	34.5	30.4	31.9	33.3	27.8	30.0	32.1	32.3	32.2	26.5	29.9	30.7	26.6	26.5	28.8	29.5	25.1	27.1	27.4	20.5	26.6	23.1	20.7		
	0~82.7	0~82.7	0~82.7	0~82.7	0~82.7	0~82.7	0~82.7	0~82.7	0~82.7	0~82.7	0~82.7	0~82.7	0~82.7	0~82.7	0~82.7	0~82.7	0~82.7	0~82.7	0~82.7	0~82.7	0~82.7	0~82.7	0~82.7	0~82.7	0~82.7	0~82.7		
	伸長状態(伸縮割合%)																											
2段目ブーム	0	0	0	0	46	0	0	0	46	0	0	0	92	46	0	0	92	46	0	0	92	46	0	92	92	46		
3段目ブーム	0	46	0	0	46	46	0	0	46	46	0	0	46	46	46	0	46	46	46	0	46	46	0	46	46	46		
4段目ブーム	0	0	46	0	0	46	0	0	46	46	46	46	0	46	46	46	0	46	46	46	46	46	46	46	46	46		
5段目ブーム	0	0	0	0	0	0	46	0	0	46	46	46	0	46	46	92	46	46	46	92	46	46	92	46	46	92		
6段目ブーム	0	0	0	46	0	0	46	92	0	0	46	92	0	0	46	92	0	46	92	92	46	92	92	46	92	92		
標準フック	90t×2	90t	90t	50t	90t	90t	50t	50t	90t	90t	50t	50t	90t	90t	50t	50t	90t	90t	50t	50t	50t	50t	50t	50t	50t	50t		
フック質量	1120kg×2	1120kg	1120kg	600kg	1120kg	1120kg	600kg	600kg	1120kg	1120kg	600kg	600kg	1120kg	1120kg	600kg	600kg	1120kg	1120kg	600kg	600kg	600kg	600kg	600kg	600kg	600kg	600kg		
標準巻掛本数	24	13	13	7	13	13	7	5	11	8	7	5	8	8	6	4	7	6	5	4	5	4	3	4	4	3		

注) カウンタウエイト25t、アウトリガ張出幅5.0m ※印はアタッチメント付き、ジブ無しでの値です。

■N性能  
6段ESPブーム

性能ブロック	1	9	10	1	9	10	2	1	10	11	2	1	10	11	2	1	11	2	3	1	2	3	1	5	3	4		
性能番号	1	26	28	2	27	29	12	3	30	32	13	4	31	33	14	5	34	15	17	6	16	18	7	21	19	20		
ブーム長さ(m) 作業半径(m)	※12.8	17.1			21.4				25.8				30.1				34.4				38.7			43.0				
2.7	97.0																											
3.0	90.3	86.9	86.9	45.5	86.9	85.6	46.6	34.1																				
3.5	80.8	81.2	81.7	42.8	80.9	80.2	46.6	32.0	70.0	50.0	46.6	34.7																
4.0	72.7	73.1	73.6	40.5	72.9	73.8	46.0	29.9	70.0	50.0	46.6	33.0																
4.5	65.5	66.0	66.6	38.3	65.7	66.7	44.0	28.0	66.5	50.0	45.7	31.1	54.3	50.0	42.4	26.6												
5.0	59.1	59.5	60.1	36.4	59.2	60.3	41.6	26.3	60.0	50.0	44.0	29.2	51.3	50.0	42.4	25.4	44.0	38.0	29.5	25.1								
6.0	43.6	44.2	45.1	33.1	43.8	45.4	37.2	23.5	45.0	47.1	40.9	26.0	44.6	46.4	42.4	23.1	42.2	38.0	28.6	23.4	32.8	27.4	20.5					
7.0	32.2	32.8	33.5	30.4	32.4	33.8	33.6	21.2	33.4	35.3	36.7	23.3	33.0	34.7	36.6	20.6	34.1	35.9	26.8	21.9	32.8	26.9	20.5	27.1	23.1	20.7		
8.0	25.0	25.5	26.2	27.5	25.1	26.4	28.7	19.3	26.1	27.8	29.0	21.2	25.7	27.2	28.9	18.6	26.7	28.3	24.9	20.5	27.8	25.5	20.0	27.1	23.1	20.3		
9.0	20.0	20.4	21.1	22.3	20.1	21.3	23.4	17.7	21.0	22.6	23.8	19.4	20.6	22.0	23.7	16.9	21.5	23.1	23.3	19.1	22.6	24.0	18.5	22.7	23.1	19.4		
10.0	16.4	16.7	17.4	18.5	16.4	17.6	19.6	16.3	17.2	18.7	19.9	17.8	16.9	18.3	19.8	15.5	17.8	19.2	20.5	17.8	18.7	20.1	17.2	18.8	19.5	18.5		
11.0		13.9	14.5	15.6	13.6	14.7	16.6	15.1	14.4	15.8	16.9	16.5	14.1	15.4	16.8	14.3	14.9	16.3	17.5	16.5	15.8	17.1	16.0	15.9	16.5	17.5		
12.0		11.7	12.3	13.3	11.4	12.5	14.3	14.1	12.1	13.5	14.6	15.3	11.8	13.1	14.5	13.2	12.6	14.0	15.2	15.3	13.5	14.7	14.9	13.6	14.2	15.2		
14.0		8.4	9.0	9.9	8.1	9.2	10.8	10.9	8.8	10.1	11.1	11.8	8.5	9.7	11.0	11.5	9.2	10.6	11.7	12.3	10.1	11.3	12.2	10.2	10.7	11.7		
16.0					5.7	6.8	8.4	8.5	6.5	7.8	8.7	9.3	6.2	7.3	8.6	9.5	6.9	8.1	9.2	9.8	7.7	8.8	9.7	7.8	8.3	9.2		
18.0					3.9	5.1	6.7	6.7	4.6	6.0	6.9	7.5	4.2	5.6	6.8	7.7	5.1	6.4	7.4	7.9	5.9	7.0	7.9	6.0	6.5	7.4		
20.0									3.2	4.6	5.6	6.1	2.7	4.1	5.4	6.3	3.5	5.0	6.0	6.5	4.5	5.6	6.5	4.5	5.1	6.0		
22.0									2.0	3.4	4.5	5.0	1.5	2.9	4.3	5.2	2.3	3.8	4.9	5.4	3.2	4.5	5.4	3.3	4.0	4.9		
24.0														1.9	3.3	4.3	1.3	2.8	4.0	4.5	2.2	3.5	4.4	2.3	2.9	3.9		
26.0														1.1	2.5	3.5		2.0	3.2	3.8	1.4	2.7	3.7	1.5	2.1	3.1		
28.0																		1.3	2.5	3.1		2.0	3.0		1.4	2.4		
30.0																			1.9	2.5		1.4	2.3		1.8			
32.0																									1.8	1.2		
34.0																								1.4				
36.0																												
38.0																												
40.0																												
42.0																												
44.0																												
46.0																												
48.0																												
50.0																												
52.0																												
54.0																												
56.0																												
ピン無最大荷重 ブーム傾斜角の範囲 (無負荷時) (度)	31.9	32.7	34.4	34.5	30.4	31.9	33.3	27.8	30.0	32.1	32.3	32.2	26.5	29.9	30.7	26.6	26.5	28.8	29.5	25.1	27.1	27.4	20.5	26.6	23.1	20.7		
	0~82.7	0~82.7	0~82.7	0~82.7	0~82.7	0~82.7	0~82.7	0~82.7	0~82.7	0~82.7	0~82.7	0~82.7	27~82.7	0~82.7	0~82.7	0~82.7	33~82.7	23~82.7	0~82.7	0~82.7	0~82.7	36~82.7	14~82.7	0~82.7	44~82.7	38~82.7	25~82.7	
	伸長状態(伸縮割合%)																											
2段目ブーム	0	0	0	0	46	0	0	0	46	0	0	0	92	46	0	0	92	46	0	0	92	46	0	92	92	46	46	
3段目ブーム	0	46	0	0	46	46	0	0	46	46	0	0	46	46	46	0	46	46	46	0	46	46	0	46	46	46	46	
4段目ブーム	0	0	46	0	0	46	0	0	46	46	46	46	0	46	46	46	0	46	46	46	46	46	46	46	46	46	46	
5段目ブーム	0	0	0	0	0	0	46	0	0	46	46	46	0	46	46	46	92	46	46	46	92	46	46	92	46	46	92	
6段目ブーム	0	0	0	46	0	0	46	92	0	0	46	92	0	0	46	92	0	46	92	92	46	92	92	46	92	92	92	
標準フック	90t×2	90t	90t	50t	90t	90t	50t	50t	90t	90t	50t	50t	90t	90t	50t	50t	90t	90t	50t	50t	50t	50t	50t	50t	50t	50t	50t	
フック質量	1120kg×2	1120kg	1120kg	600kg	1120kg	1120kg	600kg	600kg	1120kg	1120kg	600kg	600kg	1120kg	1120kg	600kg	600kg	1120kg	1120kg	600kg	600kg	600kg	600kg	600kg	600kg	600kg	600kg	600kg	
標準巻掛本数	24	13	13	7	13	13	7	5	11	8	7	5	8	8	6	4	7	6	5	4	5	4	3	4	4	3		

注) カウンタウエイト15t、アウトリガ張出幅5.0m ※印はアタッチメント付き、ジブ無しでの値です。

■O性能  
6段ESPブーム

性能ブロック	1	9	10	1	9	10	2	1	10	11	2	1	10	11	2	1	11	2	3	1	2	3	1	5	3	4	
性能番号	1	26	28	2	27	29	12	3	30	32	13	4	31	33	14	5	34	15	17	6	16	18	7	21	19	20	
ブーム長さ(m) 作業半径 (m)	※12.8	17.1			21.4				25.8				30.1				34.4				38.7			43.0			
2.7	94.1																										
3.0	87.4	86.9	86.9	45.5	86.9	85.6	46.6	34.1																			
3.5	77.9	78.3	78.8	42.8	78.1	79.0	46.6	32.0	70.0	50.0	46.6	34.7															
4.0	68.9	69.4	69.9	40.5	69.1	70.1	46.0	29.9	69.9	50.0	46.6	33.0															
4.5	61.4	61.9	62.5	38.3	61.6	62.7	44.0	28.0	62.4	50.0	45.7	31.1	54.3	50.0	42.4	26.6											
5.0	48.0	48.9	49.9	36.4	48.3	50.3	41.6	26.3	49.8	50.0	44.0	29.2	49.3	50.0	42.4	25.4	44.0	38.0	29.5	25.1							
6.0	32.1	32.8	33.7	33.1	32.4	34.0	36.8	23.5	33.5	35.7	37.3	26.0	33.1	35.0	37.1	23.1	34.3	36.4	28.6	23.4	32.8	27.4	20.5				
7.0	23.3	23.8	24.6	26.1	23.5	24.9	27.4	21.2	24.5	26.4	27.8	23.3	24.1	25.8	27.7	20.6	25.2	27.0	26.8	21.9	26.4	26.9	20.5	26.5	23.1	20.7	
8.0	17.7	18.2	18.9	20.2	17.8	19.1	21.4	19.3	18.8	20.5	21.8	21.2	18.4	19.9	21.7	18.6	19.4	21.0	22.5	20.5	20.5	22.0	20.0	20.6	21.3	20.3	
9.0	13.9	14.2	14.9	16.1	13.9	15.2	17.2	17.4	14.8	16.4	17.6	18.4	14.5	15.9	17.5	16.9	15.4	16.9	18.3	19.0	16.4	17.8	18.5	16.5	17.2	18.3	
10.0	11.1	11.4	12.0	13.1	11.1	12.2	14.2	14.3	11.9	13.4	14.5	15.3	11.6	12.9	14.4	15.5	12.4	13.9	15.2	15.8	13.4	14.7	15.8	13.5	14.1	15.2	
11.0		9.2	9.8	10.9	8.9	10.0	11.9	12.0	9.7	11.1	12.2	12.9	9.3	10.6	12.1	13.2	10.2	11.6	12.8	13.5	11.1	12.4	13.4	11.2	11.8	12.8	
12.0		7.4	8.0	9.1	7.2	8.2	10.1	10.2	7.9	9.3	10.4	11.0	7.6	8.8	10.3	11.3	8.4	9.8	11.0	11.6	9.3	10.5	11.5	9.4	10.0	10.9	
14.0		4.8	5.5	6.4	4.4	5.7	7.4	7.4	5.3	6.6	7.6	8.3	4.9	6.2	7.5	8.5	5.8	7.1	8.2	8.8	6.6	7.8	8.7	6.7	7.3	8.2	
16.0					2.4	3.7	5.5	5.5	3.3	4.8	5.7	6.3	2.8	4.3	5.6	6.6	3.7	5.2	6.3	6.8	4.7	5.9	6.8	4.8	5.4	6.2	
18.0					1.0	2.2	4.1	4.1	1.8	3.2	4.3	4.9	1.3	2.7	4.2	5.1	2.2	3.7	4.8	5.4	3.1	4.4	5.3	3.2	3.9	4.8	
20.0									2.0	3.2	3.8							2.5	3.7	4.2	1.9	3.3	4.2	2.0	2.6	3.7	
22.0										1.1	2.2	2.9															
24.0																											
26.0																											
28.0																											
30.0																											
32.0																											
34.0																											
36.0																											
38.0																											
40.0																											
42.0																											
44.0																											
46.0																											
48.0																											
50.0																											
52.0																											
54.0																											
56.0																											
ピン無最大荷重 ブーム際荷重の範囲 (無負荷時) (度)	31.9	32.7	34.4	34.5	30.4	31.9	33.3	27.8	30.0	32.1	32.2	32.2	26.5	29.9	30.7	26.6	26.5	28.8	29.5	25.1	27.1	27.4	20.5	26.6	23.1	20.7	
	0~82.7	0~82.7	0~82.7	0~82.7	5~82.7	0~82.7	0~82.7	0~82.7	28~82.7	0~82.7	0~82.7	0~82.7	45~82.7	35~82.7	9~82.7	0~82.7	48~82.7	38~82.7	15~82.7	22~82.7	51~82.7	40~82.7	21~82.7	58~82.7	53~82.7	44~82.7	
伸長状態(伸縮割合%)																											
2段目ブーム	0	0	0	0	46	0	0	0	46	0	0	0	92	46	0	0	92	46	0	0	92	46	0	92	92	46	
3段目ブーム	0	46	0	0	46	46	0	0	46	46	0	0	46	46	46	0	46	46	46	0	46	46	0	46	46	46	
4段目ブーム	0	0	46	0	0	46	0	0	46	46	46	0	46	46	46	0	46	46	46	46	46	46	46	46	46	46	
5段目ブーム	0	0	0	0	0	0	46	0	0	46	46	46	0	46	46	92	46	46	46	92	46	46	92	46	46	92	
6段目ブーム	0	0	0	46	0	0	46	92	0	0	46	92	0	0	46	92	0	46	92	92	46	92	92	46	92	92	
標準フック	90t×2	90t	90t	50t	90t	90t	50t	50t	90t	90t	50t	50t	90t	90t	50t	50t	90t	90t	50t	50t	50t	50t	50t	50t	50t	50t	
フック質量	1120kg×2	1120kg	1120kg	600kg	1120kg	1120kg	600kg	600kg	1120kg	1120kg	600kg	600kg	1120kg	1120kg	600kg	600kg	1120kg	1120kg	600kg	600kg	600kg	600kg	600kg	600kg	600kg	600kg	
標準巻掛本数	24	13	13	7	13	13	7	5	11	8	7	5	8	8	6	4	7	6	5	4	5	4	3	4	4	3	

注) カウンタウエイト6t、アウトリガ張出幅5.0m ※印はアタッチメント付き、ジブ無しでの値です。

■P性能  
6段ESPブーム

性能ブロック	1	9	10	1	9	10	2	1	10	11	2	1	10	11	2	1	11	2	3	1	2	3	1	5	3	4		
性能番号	1	26	28	2	27	29	12	3	30	32	13	4	31	33	14	5	34	15	17	6	16	18	7	21	19	20		
ブーム長さ(m) 作業半径(m)	※12.8	17.1			21.4				25.8				30.1				34.4				38.7			43.0				
2.7	91.9																											
3.0	85.3	85.7	86.2	45.5	85.4	85.6	46.6	34.1																				
3.5	74.6	75.1	75.7	42.8	74.8	75.9	46.6	32.0	70.0	50.0	46.6	34.7																
4.0	65.7	66.2	66.8	40.5	65.9	67.0	46.0	29.9	66.7	50.0	46.6	33.0																
4.5	48.3	49.2	50.4	38.3	48.6	50.9	44.0	28.0	50.3	50.0	45.7	31.1	49.7	50.0	42.4	26.6												
5.0	37.1	37.9	39.0	36.4	37.4	39.4	41.6	26.3	38.8	41.4	43.3	29.2	38.3	40.6	42.4	25.4	39.7	38.0	29.5	25.1								
6.0	24.3	24.9	25.8	27.4	24.5	26.2	28.9	23.5	25.7	27.8	29.4	26.0	25.3	27.1	29.3	23.1	26.5	28.5	28.6	23.4	27.8	27.4	20.5					
7.0	17.2	17.7	18.5	19.9	17.4	18.8	21.3	21.2	18.4	20.3	21.7	22.6	18.0	19.7	21.6	20.6	19.1	20.9	22.5	21.9	20.3	21.9	20.5	20.4	21.2	20.7		
8.0	12.7	13.2	13.9	15.2	12.8	14.2	16.4	16.5	13.8	15.5	16.8	17.6	13.4	14.9	16.7	17.9	14.4	16.0	17.5	18.2	15.5	17.0	18.2	15.6	16.3	17.5		
9.0	9.6	10.0	10.7	11.9	9.7	10.9	13.0	13.1	10.6	12.2	13.4	14.1	10.2	11.7	13.3	14.4	11.1	12.7	14.0	14.7	12.2	13.6	14.7	12.3	12.9	14.0		
10.0	7.4	7.7	8.3	9.5	7.4	8.6	10.5	10.7	8.2	9.7	10.9	11.6	7.9	9.2	10.8	11.9	8.8	10.2	11.5	12.2	9.7	11.1	12.1	9.8	10.5	11.5		
11.0		5.9	6.5	7.6	5.7	6.8	8.6	8.8	6.5	7.9	9.0	9.7	6.1	7.4	8.9	9.9	6.9	8.3	9.6	10.2	7.9	9.1	10.2	8.0	8.6	9.6		
12.0		4.4	5.1	6.1	4.1	5.4	7.2	7.3	5.0	6.4	7.5	8.1	4.6	6.0	7.4	8.4	5.5	6.9	8.1	8.7	6.4	7.6	8.6	6.5	7.1	8.0		
14.0		2.1	2.8	3.9	1.8	3.1	5.0	5.0	2.7	4.3	5.2	5.9	3.7	5.1	6.1	6.1	3.2	4.7	5.8	6.4	4.2	5.4	6.3	4.3	4.9	5.8		
16.0						1.4	3.4	3.4		2.5	3.7	4.3		2.0	3.6	4.5		3.0	4.2	4.8		3.8	4.7		3.2	4.2		
18.0							2.1	2.1		1.3	2.4	3.1			2.3	3.3		1.7	3.0	3.6		2.5	3.5			3.0		
20.0											1.4	2.1				2.3			2.0	2.6		1.5	2.5			1.9		
22.0												1.3				1.5			1.2	1.8			1.7			1.5		
24.0																				1.1			1.0					
26.0																												
28.0																												
30.0																												
32.0																												
34.0																												
36.0																												
38.0																												
40.0																												
42.0																												
44.0																												
46.0																												
48.0																												
50.0																												
52.0																												
54.0																												
56.0																												
ピン無最大荷重 ブーム際荷重の範囲 (無負荷時) (度)	31.9	32.7	34.4	34.5	30.4	31.9	33.3	27.8	30.0	32.1	32.3	32.2	26.5	29.9	30.7	26.6	26.5	28.8	29.5	25.1	27.1	27.4	20.5	26.6	23.1	20.7		
	0~82.7	0~82.7	0~82.7	0~82.7	35~82.7	23~82.7	0~82.7	0~82.7	43~82.7	33~82.7	12~82.7	0~82.7	56~82.7	47~82.7	36~82.7	21~82.7	60~82.7	50~82.7	38~82.7	32~82.7	61~82.7	52~82.7	40~82.7	66~82.7	63~82.7	56~82.7		
	伸長状態(伸縮割合%)																											
2段目ブーム	0	0	0	0	46	0	0	0	46	0	0	0	92	46	0	0	92	46	0	0	92	46	0	92	92	46	46	
3段目ブーム	0	46	0	0	46	46	0	0	46	46	0	0	46	46	46	0	46	46	46	0	46	46	0	92	46	46	46	
4段目ブーム	0	0	46	0	0	46	0	0	46	46	46	46	0	46	46	46	0	46	46	46	46	46	46	92	46	46	46	
5段目ブーム	0	0	0	0	0	0	46	0	0	46	46	46	0	46	46	92	46	46	46	92	46	46	92	46	46	46	92	
6段目ブーム	0	0	0	46	0	0	46	92	0	0	46	92	0	0	46	92	0	46	92	92	46	92	92	46	92	92	92	
標準フック	90t×2	90t	90t	50t	90t	90t	50t	50t	90t	90t	50t	50t	90t	90t	50t	50t	90t	90t	50t	50t	50t	50t	50t	50t	50t	50t	50t	
フック質量	1120kg×2	1120kg	1120kg	600kg	1120kg	1120kg	600kg	600kg	1120kg	1120kg	600kg	600kg	1120kg	1120kg	600kg	600kg	1120kg	1120kg	600kg	600kg	1120kg	1120kg	600kg	600kg	600kg	600kg	600kg	
標準巻掛本数	24	13	13	7	13	13	7	5	11	8	7	5	8	8	6	4	7	6	5	4	5	4	3	4	4	3		

注) カウンタウエイト0t、アウトリガ張出幅5.0m ※印はアタッチメント付き、ジブ無しでの値です。





■R性能  
6段ESPブーム

性能ブロック	1	9	10	1	9	10	2	1	10	11	2	1	10	11	2	1	11	2	3	1	2	3	1	5	3	4				
性能番号	1	26	28	2	27	29	12	3	30	32	13	4	31	33	14	5	34	15	17	6	16	18	7	21	19	20				
ブーム長さ(m)	※12.8		17.1			21.4				25.8				30.1				34.4				38.7			43.0					
作業半径(m)	87.1		80.6			81.0				81.6				45.5				80.8				81.7			46.6			34.1		
2.7																														
3.0																														
3.5																														
4.0																														
4.5																														
5.0																														
6.0																														
7.0																														
8.0																														
9.0																														
10.0																														
11.0																														
12.0																														
14.0																														
16.0																														
18.0																														
20.0																														
22.0																														
24.0																														
26.0																														
28.0																														
30.0																														
32.0																														
34.0																														
36.0																														
38.0																														
40.0																														
42.0																														
44.0																														
46.0																														
48.0																														
50.0																														
52.0																														
54.0																														
56.0																														
ピン無最大荷重	31.9	32.7	34.4	34.5	30.4	31.9	33.3	27.8	30.0	32.1	32.2	26.5	29.9	30.7	26.6	26.5	28.8	29.5	25.1	27.1	27.4	20.5	26.6	23.1	20.7					
ブーム稼働時の範囲(無負荷時) (度)	0~82.7	0~82.7	0~82.7	0~82.7	31~82.7	13~82.7	0~82.7	0~82.7	40~82.7	27~82.7	0~82.7	0~82.7	53~82.7	44~82.7	32~82.7	9~82.7	57~82.7	47~82.7	34~82.7	27~82.7	59~82.7	48~82.7	36~82.7	64~82.7	61~82.7	53~82.7				
伸長状態(伸縮割合%)																														
2段目ブーム	0	0	0	0	46	0	0	0	46	0	0	0	92	46	0	0	92	46	0	0	92	46	0	92	92	46				
3段目ブーム	0	46	0	0	46	46	0	0	46	46	0	0	46	46	46	0	46	46	46	0	46	46	0	46	46	46				
4段目ブーム	0	0	46	0	0	46	0	0	46	46	46	0	46	46	46	0	46	46	46	46	46	46	46	46	46	46				
5段目ブーム	0	0	0	0	0	0	46	0	0	46	46	46	0	46	46	92	46	46	46	92	46	46	92	46	46	92				
6段目ブーム	0	0	0	46	0	0	46	92	0	0	46	92	0	0	46	92	0	46	92	92	46	92	92	46	92	92				
標準フック	90t×2	90t	90t	50t	90t	90t	50t	50t	90t	90t	50t	50t	90t	90t	50t	50t	90t	90t	50t	50t	50t	50t	50t	50t	50t	50t				
フック質量	1120kg×2	1120kg	1120kg	600kg	1120kg	1120kg	600kg	600kg	1120kg	1120kg	600kg	600kg	1120kg	1120kg	600kg	600kg	1120kg	1120kg	600kg	600kg	600kg	600kg	600kg	600kg	600kg	600kg				
標準巻掛本数	24	13	13	7	13	13	7	5	11	8	7	5	8	8	6	4	7	6	5	4	5	4	3	4	4	3				

注) カウンタウエイト6t、アウトリガ張出幅4.1m ※印はアタッチメント付き、ジブ無しでの値です。

■S性能

6段ESPブーム

性能ブロック	1	9	10	1	9	10	2	1	10	11	2	1	10	11	2	1	10	11	2	3	1	2	3	1	5	3	4
性能番号	1	26	28	2	27	29	12	3	30	32	13	4	31	33	14	5	34	15	17	6	16	18	7	21	19	20	
ブーム長さ(m) 作業半径(m)	※12.8	17.1			21.4				25.8				30.1				34.4				38.7			43.0			
2.7	84.5																										
3.0	77.7	78.2	78.9	45.5	78.0	79.1	46.6	34.1																			
3.5	59.3	60.4	61.9	42.8	59.8	62.4	46.6	32.0	61.7	50.0	46.6	34.7															
4.0	42.1	43.0	44.2	40.5	42.5	44.6	46.0	29.9	44.1	46.9	46.6	33.0															
4.5	32.0	32.7	33.7	35.6	32.3	34.1	37.3	28.0	33.6	36.0	37.8	31.1	33.1	35.3	37.7	26.6											
5.0	25.2	25.9	26.8	28.5	25.5	27.2	30.0	26.3	26.7	28.9	30.5	29.2	26.3	28.2	30.4	25.4	27.5	29.6	29.5	25.1							
6.0	16.9	17.5	18.3	19.7	17.1	18.6	21.0	21.2	18.2	20.0	21.4	22.4	17.8	19.4	21.3	22.7	18.8	20.7	22.3	23.1	20.0	21.7	20.5				
7.0	12.0	12.4	13.2	14.5	12.1	13.4	15.6	15.8	13.1	14.8	16.0	16.9	12.7	14.2	15.9	17.2	13.7	15.3	16.8	17.5	14.8	16.2	17.5	14.9	15.6	16.7	
8.0	8.7	9.1	9.8	11.0	8.8	10.0	12.1	12.2	9.7	11.3	12.4	13.2	9.3	10.7	12.3	13.5	10.2	11.8	13.1	13.8	11.3	12.6	13.8	11.4	12.0	13.1	
9.0	6.4	6.7	7.4	8.5	6.5	7.6	9.5	9.7	7.3	8.8	9.9	10.6	7.0	8.3	9.8	10.9	7.8	9.2	10.5	11.2	8.8	10.1	11.1	8.8	9.5	10.5	
10.0	4.5	5.0	5.6	6.6	4.6	5.8	7.6	7.8	5.5	6.9	8.0	8.7	5.2	6.4	7.9	8.9	6.0	7.4	8.6	9.2	6.9	8.1	9.2	7.0	7.6	8.6	
11.0		3.4	4.1	5.2	3.1	4.4	6.2	6.3	4.0	5.4	6.5	7.1		5.0	6.4	7.4	4.5	5.9	7.1	7.7	5.4	6.6	7.6	5.5	6.1	7.0	
12.0		2.1	2.8	4.0	1.8	3.1	5.0	5.1	2.7	4.3	5.3	5.9		3.8	5.2	6.2		4.7	5.9	6.4	4.3	5.4	6.4		4.9	5.8	
14.0				2.0		1.2	3.2	3.3		2.4	3.5	4.1			3.4	4.4		2.9	4.1	4.6		3.7	4.6			4.0	
16.0							1.7	1.8						2.1	2.8					2.7	3.3		2.2	3.3		2.7	
18.0													1.0	1.7						1.6	2.3			2.2			
20.0																					1.4				1.3		
22.0																											
24.0																											
26.0																											
28.0																											
30.0																											
32.0																											
34.0																											
36.0																											
38.0																											
40.0																											
42.0																											
44.0																											
46.0																											
48.0																											
50.0																											
52.0																											
54.0																											
56.0																											
ピン無最大荷重	31.9	32.7	34.4	34.5	30.4	31.9	33.3	27.8	30.0	32.1	32.3	32.2	26.5	29.9	30.7	26.6	26.5	28.8	29.5	25.1	27.1	27.4	20.5	26.6	23.1	20.7	
ブーム稼働時の範囲 (無負荷時) (度)	0~82.7	18~82.7	0~82.7	0~82.7	45~82.7	38~82.7	13~82.7	13~82.7	52~82.7	44~82.7	34~82.7	23~82.7	63~82.7	56~82.7	46~82.7	37~82.7	66~82.7	58~82.7	47~82.7	44~82.7	67~82.7	60~82.7	49~82.7	72~82.7	69~82.7	63~82.7	
伸長状態(伸縮割合%)																											
2段目ブーム	0	0	0	0	46	0	0	0	46	0	0	0	92	46	0	0	92	46	0	0	92	46	0	92	92	46	46
3段目ブーム	0	46	0	0	46	46	0	0	46	46	0	0	46	46	46	0	46	46	46	0	46	46	0	46	46	46	46
4段目ブーム	0	0	46	0	0	46	0	0	46	46	46	46	0	46	46	46	0	46	46	46	46	46	46	92	46	46	46
5段目ブーム	0	0	0	0	0	0	46	0	0	46	46	46	0	46	46	92	46	46	46	92	46	46	92	46	46	46	92
6段目ブーム	0	0	0	46	0	0	46	92	0	0	46	92	0	0	46	92	0	46	92	92	46	92	92	46	92	92	92
標準フック	90t×2	90t	90t	50t	90t	90t	50t	50t	90t	90t	50t	50t	90t	90t	50t	50t	90t	90t	50t	50t	50t	50t	50t	50t	50t	50t	50t
フック質量	1120kg×2	1120kg	1120kg	600kg	1120kg	1120kg	600kg	600kg	1120kg	1120kg	600kg	600kg	1120kg	1120kg	600kg	600kg	1120kg	1120kg	600kg	600kg	600kg	600kg	600kg	600kg	600kg	600kg	600kg
標準巻掛本数	24	13	13	7	13	13	7	5	11	8	7	5	8	8	6	4	7	6	5	4	5	4	3	4	4	3	

注) カウンタウエイト0t、アウトリガ張出幅4.1m ※印はアタッチメント付き、ジブ無しでの値です。

■T性能

6段ESPブーム

単位:t

性能ブロック	1	9	10	1	9	10	2	1	10	11	2	1
性能番号	1	26	28	2	27	29	12	3	30	32	13	4
ブーム長さ(m) 作業半径(m)	※12.8			17.1			21.4			25.8		
2.7	41.2											
3.0	32.8	33.7	34.8	36.7	33.2	35.2	38.5	34.1				
3.5	23.8	24.5	25.5	27.2	24.1	25.8	28.7	29.0	25.4	27.6	29.2	30.3
4.0	18.1	18.7	19.6	21.1	18.3	19.9	22.5	22.7	19.5	21.4	22.9	23.9
4.5	14.1	14.7	15.5	16.9	14.4	15.8	18.2	18.3	15.4	17.2	18.6	19.5
5.0	11.2	11.7	12.5	13.8	11.4	12.7	15.0	15.2	12.4	14.1	15.4	16.2
6.0	7.2	7.7	8.4	9.6	7.4	8.6	10.7	10.8	8.3	9.8	11.0	11.8
7.0	4.6	5.1	5.7	6.8	4.8	5.9	7.8	8.0	5.6	7.1	8.2	8.9
8.0	2.5	3.0	3.7	4.9		4.0	5.8	6.0		5.1	6.1	6.8
9.0	1.0		2.1	3.4			4.4	4.5		3.7	4.7	5.3
10.0				2.1			3.2	3.3			3.5	4.2
11.0				1.1			2.2	2.3			2.5	3.2
12.0							1.3	1.4				2.4
14.0												
16.0												
18.0												
20.0												
22.0												
24.0												
26.0												
28.0												
30.0												
32.0												
34.0												
36.0												
38.0												
40.0												
42.0												
44.0												
46.0												
48.0												
50.0												
52.0												
54.0												
56.0												
ピン無最大荷重	31.9	32.7	34.4	34.5	30.4	31.9	33.3	27.8	30.0	32.1	32.3	32.2
ブーム稼働の範囲 (無負荷時) (度)	29~82.7	47~82.7	43~82.7	39~82.7	62~82.7	57~82.7	47~82.7	46~82.7	67~82.7	61~82.7	54~82.7	50~82.7
伸長状態(伸縮割合%)												
2段目ブーム	0	0	0	0	46	0	0	0	46	0	0	0
3段目ブーム	0	46	0	0	46	46	0	0	46	46	0	0
4段目ブーム	0	0	46	0	0	46	0	0	46	46	46	0
5段目ブーム	0	0	0	0	0	0	46	0	0	46	46	46
6段目ブーム	0	0	0	46	0	0	46	92	0	0	46	92
標準フック	90t×2	90t	90t	50t	90t	90t	50t	50t	90t	90t	50t	50t
フック質量	1120kg×2	1120kg	1120kg	600kg	1120kg	1120kg	600kg	600kg	1120kg	1120kg	600kg	600kg
標準巻掛本数	24	13	13	7	13	13	7	5	11	8	7	5

注) カウンタウエイト0t、アウトリガ張出幅2.5m ※印はアタッチメント付き、ジブ無しでの値です。

## 2. 2 ジブ定格総荷重表

1. 定格総荷重は、アウトリガを水平堅土上に設置したときの値で、太線より上側はクレーンの強度に基づき、下側は、クレーンの安定に基づいています。

2. 定格総荷重表の性能区分A～O, Qは、下表のとおりです。

カウンタ ウェイト アウトリガ 張出幅	40 t	28 t	25 t	15 t	6 t	0 t
7.5 m	A	B	C	D	E	K
6.2 m	F	G	H	I	J	K
5.0 m		L	M	N	O	
4.1 m				Q		

3. 定格総荷重表中のジブ長さにおける各ジブ段の伸長状態は、下表のとおりです。

ブーム長さ	各ジブ段伸長割合 (%)				
	2 段目ブーム	3 段目ブーム	4 段目ブーム	5 段目ブーム	6 段目ブーム
12.8 m	0	0	0	0	0
25.8 m	46	46	46	0	0
34.4 m	46	46	46	46	46
43.0 m	92	92	46	46	46
56.0 m	92	92	92	92	92
60.0 m	100	100	100	100	100

4. Bピン（ブーム固定ピン）を挿入していないときの定格総荷重は、20 t に制限されます。

5. 定格総荷重は、つり具質量とフック質量（50 t フック：600kg、22 t フック：375kg、7.3 t フック：300kg）を含んだ値を示します。

6. 定格総荷重は、ブーム、ジブのたわみを含んだ実際の作業半径に基づいています。

7. 各状態における標準フックとワイヤロープ標準巻掛本数は、ジブの各定格総荷重表中に記載しています。なお、ロープ1本当りの荷重は、7.3 t 以下です。

8. 定格総荷重表は、風による影響を含んでいません。瞬間最大風速が10m/s以上の風速では、クレーン作業を中止してください。

9. 3.8mジブで作業する場合、巻掛本数1本での作業は、絶対に行わないでください。ジブが後方に転倒し危険です。

■A性能

12.8mブーム+パイフールドパワーチルトジブ

単位:t

ジブ長さ 作業半径 (m)	3.8m			10.2m			18m		
	オフセット			オフセット			オフセット		
	5°	20°	40°	5°	20°	40°	5°	20°	40°
3.0	40.0	32.7							
3.5	40.0	31.3	25.2				7.8		
4.0	40.0	30.0	24.5	14.6			7.8		
4.5	38.9	28.9	23.8	14.6			7.8		
5.0	36.8	27.8	23.2	14.6	14.1		7.8		
6.0	33.3	26.0	22.2	14.6	13.0		7.8		
7.0	30.4	24.4	21.3	14.6	12.1		7.5		
8.0	28.0	23.1	20.5	14.6	11.3	9.1	7.1		
9.0	26.0	22.0	19.9	13.8	10.6	8.7	6.7	5.2	
10.0	24.3	21.0	19.5	12.6	10.0	8.4	6.3	5.0	
11.0	22.9	20.2	19.2	11.4	9.4	8.0	6.0	4.7	
12.0	21.6	19.6		10.4	9.0	7.8	5.7	4.5	
14.0	20.0			8.9	8.2	7.3	5.1	4.1	3.5
16.0				7.8	7.6	7.0	4.6	3.8	3.3
18.0				6.9	7.1		4.2	3.5	3.1
20.0				6.1			3.9	3.3	3.0
22.0							3.5	3.1	2.9
24.0							3.3	3.0	2.8
26.0							3.1	2.9	
28.0							2.9		
30.0									
32.0									
34.0									
36.0									
38.0									
40.0									
44.0									
48.0									
52.0									
56.0									
60.0									
64.0									
θ (°)	12~77.5	35~82.7	43~82.7	15~80.5	35~82.7	49~82.7	12~82.7	33~82.7	48~82.7
標準フック	50t			22t					
フック質量	600kg			375kg					
標準巻掛本数	6			2					

注) カウンタウエイト40t、アウトリガ張出幅7.5m

■A性能

25.8mブーム+パイフールドパワーチルトジブ

単位:t

ジブ長さ 作業半径 (m)	3.8m			10.2m			18m		
	オフセット			オフセット			オフセット		
	5°	20°	40°	5°	20°	40°	5°	20°	40°
3.0									
3.5									
4.0									
4.5			34.4						
5.0			33.5						7.4
6.0			31.9	25.0					7.4
7.0	35.0	30.4	24.2	14.6	14.6				7.4
8.0	35.0	29.1	23.5	14.6	13.9				7.4
9.0	35.0	27.9	22.9	14.6	13.2				7.4
10.0	34.3	26.8	22.3	14.6	12.6	9.3			7.1
11.0	32.5	25.9	21.8	14.6	12.0	9.0			6.9
12.0	30.8	25.0	21.3	14.6	11.5	8.8			6.6
14.0	27.2	23.4	20.5	14.6	10.6	8.3			6.1
16.0	22.5	22.2	19.9	13.4	9.8	7.9			5.7
18.0	18.6	18.8	18.9	12.3	9.2	7.6			5.3
20.0	15.6	15.7	15.8	11.1	8.6	7.3			4.9
22.0	13.2	13.3	13.4	9.9	8.1	7.1			4.6
24.0	11.3	11.4		9.0	7.8	6.9			4.3
26.0	9.7			8.2	7.4	6.8			4.0
28.0				7.5	7.1				3.8
30.0				6.9	6.9				3.6
32.0				6.4	6.8				3.4
34.0									3.3
36.0									3.2
38.0									3.0
40.0									2.9
44.0									
48.0									
52.0									
56.0									
60.0									
64.0									
θ (°)	18~77.5	29~82.7	40~82.7	18~80.5	21~82.7	45~82.7	16~82.7	29~82.7	45~82.7
標準フック	50t			22t					
フック質量	600kg			375kg					
標準巻掛本数	5			2					

注) カウンタウエイト40t、アウトリガ張出幅7.5m

■A性能

34.4mブーム+バイフォールドパワーチルトジブ

単位:t

ジブ長さ 作業半径 (m)	3.8m			10.2m			18m		
	オフセット			オフセット			オフセット		
	5°	20°	40°	5°	20°	40°	5°	20°	40°
3.0									
3.5									
4.0									
4.5									
5.0									
6.0									
7.0		17.8	16.3				5.9		
8.0		16.9	15.6	13.4			5.9		
9.0	17.4	16.2	15.0	13.4	12.1		5.9		
10.0	16.6	15.5	14.4	13.4	11.5		5.9		
11.0	15.9	14.9	13.9	12.9	11.0		5.9		
12.0	15.2	14.3	13.4	12.4	10.6	9.0	5.9		
14.0	14.1	13.3	12.6	11.3	9.8	8.5	5.9	4.3	
16.0	13.2	12.5	11.9	10.4	9.1	8.0	5.7	4.1	
18.0	12.4	11.8	11.3	9.7	8.6	7.6	5.4	3.9	3.2
20.0	11.7	11.2	10.8	9.1	8.1	7.2	5.1	3.7	3.0
22.0	11.2	10.8	10.4	8.5	7.6	6.9	4.8	3.6	2.9
24.0	10.7	10.3	10.1	8.0	7.3	6.6	4.6	3.4	2.9
26.0	10.3	10.0	9.8	7.6	6.9	6.4	4.3	3.3	2.8
28.0	9.4	9.4		7.3	6.7	6.2	4.1	3.1	2.7
30.0	8.2	8.3		7.0	6.4	6.0	3.9	3.0	2.6
32.0	7.2	7.3		6.7	6.2	5.8	3.7	2.9	2.6
34.0	6.4			6.4	6.0	5.7	3.6	2.9	2.5
36.0				6.3	5.9		3.4	2.8	2.5
38.0				5.6	5.7		3.3	2.7	2.5
40.0				5.0	5.1		3.2	2.7	2.5
44.0							3.0	2.6	
48.0							2.9		
52.0									
56.0									
60.0									
64.0									
θ (°)	19~77.5	28~82.7	45~82.7	19~80.5	21~82.7	41~82.7	18~82.7	34~82.7	46~82.7
標準フック	50t			22t			7.3t		
フック質量	600kg			375kg			300kg		
標準巻掛本数	3			2			1		

注) カウンタウエイト40t、アウトリガ張出幅7.5m

■A性能

43.0mブーム+バイフォールドパワーチルトジブ

ジブ長さ 作業半径 (m)	3.8m			
	オフセット			
	5°	20°	40°	5°
3.0				
3.5				
4.0				
4.5				
5.0				
6.0				
7.0				
8.0				
9.0			14.6	13.6
10.0			14.0	13.1
11.0			13.4	12.6
12.0		13.7	12.9	12.2
14.0		12.7	12.1	11.4
16.0		11.9	11.3	10.8
18.0		11.2	10.7	10.3
20.0		10.7	10.2	9.8
22.0		10.1	9.8	9.4
24.0		9.5	9.4	9.1
26.0		8.8	8.8	8.7
28.0		8.2	8.2	8.2
30.0		7.6	7.6	7.6
32.0		6.7	6.7	6.8
34.0		5.8	5.9	5.9
36.0		5.1	5.1	
38.0		4.4	4.4	
40.0		3.8	3.8	
44.0		2.7		
48.0				
52.0				
56.0				
60.0				
64.0				
θ (°)	9~77.5	27~82.7	41~82.7	20~
標準フック	50t			
フック質量	600kg			
標準巻掛本数	3			

注) カウンタウエイト40t、アウトリガ張出幅7.5m

■A性能

56.0mブーム+バイフォルドパワーチルトジブ

単位:t

ジブ長さ 作業半径 (m)	3.8m			10.2m			18m		
	オフセット			オフセット			オフセット		
	5°	20°	40°	5°	20°	40°	5°	20°	40°
3.0									
3.5									
4.0									
4.5									
5.0									
6.0									
7.0									
8.0									
9.0									
10.0									
11.0									
12.0		8.8							
14.0		8.3	8.0				3.9		
16.0		7.8	7.6	6.4	6.1		3.9		
18.0	7.6	7.4	7.2	6.3	5.8	5.4	3.9		
20.0	7.1	7.0	6.9	5.9	5.5	5.1	3.9	3.5	
22.0	6.7	6.6	6.5	5.6	5.2	4.9	3.9	3.4	
24.0	6.4	6.3	6.2	5.4	5.0	4.7	3.9	3.3	2.7
26.0	6.1	6.0	5.9	5.1	4.8	4.5	3.9	3.2	2.6
28.0	5.7	5.7	5.6	4.8	4.6	4.3	3.8	3.0	2.5
30.0	5.4	5.4	5.3	4.6	4.4	4.2	3.6	3.0	2.5
32.0	5.1	5.1	5.0	4.4	4.2	4.0	3.5	2.9	2.4
34.0	4.9	4.8	4.8	4.2	4.1	3.9	3.3	2.8	2.4
36.0	4.6	4.6	4.6	4.0	3.9	3.8	3.2	2.7	2.3
38.0	4.4	4.4	4.4	3.9	3.7	3.6	3.1	2.6	2.3
40.0	4.2	4.2	4.2	3.7	3.6	3.5	3.0	2.6	2.3
44.0	3.4	3.4	3.5	3.5	3.4	3.3	2.8	2.5	2.2
48.0	2.4	2.5		2.8	3.0	3.1	2.6	2.4	2.1
52.0	1.6	1.6		2.0	2.2		2.4	2.3	2.1
56.0	0.9			1.3	1.4		1.8	2.0	2.1
60.0					0.8		1.1	1.4	
64.0								0.8	
θ (°)	13~77.5	26~82.7	41~82.7	29~80.5	22~82.7	45~82.7	34~82.7	30~82.7	44~82.7
標準フック	22t			7.3t					
フック質量	375kg			300kg					
標準巻掛本数	2			1					

注) カウンタウエイト40t、アウトリガ張出幅7.5m

■A性能

60.0mブーム+バイフォルドパワーチルトジブ

単位:t

ジブ長さ 作業半径 (m)	3.8m			10.2m			18m					
	オフセット			オフセット			オフセット					
	5°	20°	40°	5°	20°	40°	5°	20°	40°			
3.0												
3.5												
4.0												
4.5												
5.0												
6.0												
7.0												
8.0												
9.0												
10.0												
11.0												
12.0												
14.0									3.6			
16.0				7.5	7.3				3.6			
18.0				7.1	6.9	5.7	5.6		3.6			
20.0				6.9	6.8	6.6	5.7	5.3	3.6			
22.0				6.5	6.4	6.3	5.4	5.1	4.7	3.6		
24.0				6.1	6.0	5.9	5.1	4.8	4.5	3.6	3.3	
26.0				5.8	5.7	5.6	4.9	4.6	4.3	3.6	3.2	
28.0				5.5	5.4	5.4	4.7	4.4	4.2	3.6	3.1	2.6
30.0				5.3	5.2	5.1	4.4	4.2	4.0	3.5	3.0	2.5
32.0				5.0	5.0	4.9	4.2	4.0	3.8	3.3	2.9	2.4
34.0				4.8	4.7	4.7	4.0	3.9	3.7	3.2	2.8	2.4
36.0				4.5	4.5	4.5	3.8	3.7	3.6	3.1	2.7	2.3
38.0				4.3	4.3	4.2	3.7	3.6	3.5	3.0	2.7	2.3
40.0				4.1	4.1	4.0	3.5	3.4	3.3	2.8	2.6	2.2
44.0				3.9	3.9	3.9	3.4	3.3	3.2	2.7	2.6	2.2
48.0				3.4	3.4	3.4	3.1	3.0	3.0	2.5	2.4	2.1
52.0				2.4	2.4		2.8	2.8	2.8	2.2	2.3	2.1
56.0				1.6	1.6		1.9	2.1	2.3		2.1	2.0
60.0				0.9	0.9		1.2	1.4		1.7	1.9	1.9
64.0								0.8		1.1	1.3	1.5
θ (°)	25~77.5	25~82.7	45~82.7	35~80.5	30~82.7	43~82.7	38~82.7	41~82.7	43~82.7			
標準フック	22t			7.3t								
フック質量	375kg			300kg								
標準巻掛本数	2			1								

注) カウンタウエイト40t、アウトリガ張出幅7.5m

■B性能

12.8mブーム+バイフォールドパワーテルトジブ

単位:t

ジブ長さ 作業半径 (m)	3.8m			10.2m			18m		
	オフセット			オフセット			オフセット		
	5°	20°	40°	5°	20°	40°	5°	20°	40°
3.0	40.0	32.7							
3.5	40.0	31.3	25.2				7.8		
4.0	40.0	30.0	24.5	14.6			7.8		
4.5	38.9	28.9	23.8	14.6			7.8		
5.0	36.8	27.8	23.2	14.6	14.1		7.8		
6.0	33.3	26.0	22.2	14.6	13.0		7.8		
7.0	30.4	24.4	21.3	14.6	12.1		7.5		
8.0	28.0	23.1	20.5	14.6	11.3	9.1	7.1		
9.0	26.0	22.0	19.9	13.8	10.6	8.7	6.7	5.2	
10.0	24.3	21.0	19.5	12.6	10.0	8.4	6.3	5.0	
11.0	22.9	20.2	19.2	11.4	9.4	8.0	6.0	4.7	
12.0	21.6	19.6		10.4	9.0	7.8	5.7	4.5	
14.0	20.0			8.9	8.2	7.3	5.1	4.1	3.5
16.0				7.8	7.6	7.0	4.6	3.8	3.3
18.0				6.9	7.1		4.2	3.5	3.1
20.0				6.1			3.9	3.3	3.0
22.0							3.5	3.1	2.9
24.0							3.3	3.0	2.8
26.0							3.1	2.9	
28.0							2.9		
30.0									
32.0									
34.0									
36.0									
38.0									
40.0									
44.0									
48.0									
52.0									
56.0									
θ (°)	12~77.5	35~82.7	43~82.7	15~80.5	35~82.7	49~82.7	12~82.7	33~82.7	48~82.7
標準フック	50t			22t					
フック質量	600kg			375kg					
標準巻掛本数	6			2					

注) カウンタウエイト28t、アウトリガ張出幅7.5m

■B性能

25.8mブーム+バイフォールドパワーテルトジブ

単位:t

ジブ長さ 作業半径 (m)	3.8m			10.2m			18m		
	オフセット			オフセット			オフセット		
	5°	20°	40°	5°	20°	40°	5°	20°	40°
3.0									
3.5									
4.0									
4.5				34.4					
5.0				33.5					7.4
6.0				31.9	25.0				7.4
7.0	35.0	30.4	24.2	14.6	14.6				7.4
8.0	35.0	29.1	23.5	14.6	13.9				7.4
9.0	35.0	27.9	22.9	14.6	13.2				7.4
10.0	34.3	26.8	22.3	14.6	12.6	9.3			7.1
11.0	32.5	25.9	21.8	14.6	12.0	9.0			6.9
12.0	28.8	25.0	21.3	14.6	11.5	8.8			6.6
14.0	22.3	22.6	20.5	14.6	10.6	8.3			6.1
16.0	17.8	18.0	18.2	13.4	9.8	7.9			5.7
18.0	14.5	14.7	14.8	12.3	9.2	7.6			5.3
20.0	12.0	12.1	12.2	11.1	8.6	7.3			4.9
22.0	10.0	10.1	10.1	9.9	8.1	7.1			4.6
24.0	8.4	8.4		9.0	7.8	6.9			4.3
26.0	7.1			8.2	7.4	6.8			4.0
28.0				7.0	7.1				3.8
30.0				6.1	6.3				3.6
32.0				5.3	5.4				3.4
34.0									3.3
36.0									3.2
38.0									3.0
40.0									2.9
44.0									
48.0									
52.0									
56.0									
θ (°)	18~77.5	29~82.7	40~82.7	18~80.5	21~82.7	45~82.7	16~82.7	29~82.7	45~82.7
標準フック	50t			22t					
フック質量	600kg			375kg					
標準巻掛本数	5			2					

注) カウンタウエイト28t、アウトリガ張出幅7.5m



■B性能

34.4mブーム+バイフォルドパワーテルトジブ

単位:t

ジブ長さ 作業半径 (m)	3.8m			10.2m			18m		
	オフセット			オフセット			オフセット		
	5°	20°	40°	5°	20°	40°	5°	20°	40°
3.0									
3.5									
4.0									
4.5									
5.0									
6.0									
7.0		17.8	16.3					5.9	
8.0		16.9	15.6	13.4				5.9	
9.0	17.4	16.2	15.0	13.4	12.1			5.9	
10.0	16.6	15.5	14.4	13.4	11.5			5.9	
11.0	15.9	14.9	13.9	12.9	11.0			5.9	
12.0	15.2	14.3	13.4	12.4	10.6	9.0		5.9	
14.0	14.1	13.3	12.6	11.3	9.8	8.5	5.9	4.3	
16.0	13.2	12.5	11.9	10.4	9.1	8.0	5.7	4.1	
18.0	12.4	11.8	11.3	9.7	8.6	7.6	5.4	3.9	3.2
20.0	11.7	11.2	10.8	9.1	8.1	7.2	5.1	3.7	3.0
22.0	11.0	10.8	10.4	8.5	7.6	6.9	4.8	3.6	2.9
24.0	9.4	9.5	9.6	8.0	7.3	6.6	4.6	3.4	2.9
26.0	8.0	8.1	8.2	7.6	6.9	6.4	4.3	3.3	2.8
28.0	6.9	7.0		7.3	6.7	6.2	4.1	3.1	2.7
30.0	5.9	6.0		6.6	6.4	6.0	3.9	3.0	2.6
32.0	5.1	5.1		5.7	6.0	5.8	3.7	2.9	2.6
34.0	4.4			5.0	5.2	5.4	3.6	2.9	2.5
36.0				4.4	4.5		3.4	2.8	2.5
38.0				3.8	3.9		3.3	2.7	2.5
40.0				3.2	3.3		3.2	2.7	2.5
44.0							3.0	2.6	
48.0							2.3		
52.0									
56.0									
θ (°)	19~77.5	28~82.7	45~82.7	19~80.5	21~82.7	41~82.7	18~82.7	34~82.7	46~82.7
標準フック	50t			22t			7.3t		
フック質量	600kg			375kg			300kg		
標準巻掛本数	3			2			1		

注) カウンタウエイト28t、アウトリガ張出幅7.5m

■B性能

43.0mブーム+バイフォルドパワーテルトジブ

単位:t

ジブ長さ 作業半径 (m)	3.8m			10.2m			18m		
	オフセット			オフセット			オフセット		
	5°	20°	40°	5°	20°	40°	5°	20°	40°
3.0									
3.5									
4.0									
4.5									
5.0									
6.0									
7.0									
8.0									
9.0					14.6	13.6			
10.0					14.0	13.1			5.5
11.0					13.4	12.6	10.6		5.5
12.0		13.7	12.9	12.2	10.6	9.8			5.5
14.0	12.7	12.1	11.4	10.4	9.2	8.0			5.5
16.0	11.9	11.3	10.8	9.8	8.6	7.6	5.5	4.1	
18.0	11.2	10.7	10.3	9.2	8.1	7.2	5.4	3.9	
20.0	10.7	10.2	9.8	8.7	7.7	6.9	5.2	3.7	3.0
22.0	10.1	9.8	9.4	8.2	7.3	6.6	4.9	3.6	2.9
24.0	8.8	8.9	9.0	7.7	7.0	6.3	4.7	3.4	2.8
26.0	7.4	7.5	7.6	7.3	6.7	6.1	4.5	3.3	2.7
28.0	6.3	6.4	6.5	6.8	6.4	5.9	4.3	3.2	2.7
30.0	5.3	5.4	5.5	5.9	6.1	5.7	4.1	3.1	2.6
32.0	4.5	4.6	4.6	5.0	5.4	5.5	3.9	3.0	2.6
34.0	3.7	3.7	3.8	4.3	4.6	4.9	3.8	2.9	2.5
36.0	2.9	3.0		3.6	3.9	4.2	3.6	2.8	2.5
38.0	2.3	2.3		2.9	3.2	3.5	3.5	2.7	2.4
40.0	1.7	1.8		2.4	2.6	2.8	3.2	2.7	2.4
44.0	0.8			1.4	1.6		2.2	2.6	2.4
48.0							1.4	1.7	2.0
52.0								0.9	
56.0									
θ (°)	9~77.5	27~82.7	41~82.7	30~80.5	32~82.7	42~82.7	36~82.7	32~82.7	42~82.7
標準フック	50t			22t			7.3t		
フック質量	600kg			375kg			300kg		
標準巻掛本数	3			2			1		

注) カウンタウエイト28t、アウトリガ張出幅7.5m

■B性能

56.0mブーム+バイフォールドパワーテルトジブ

単位:t

ジブ長さ 作業半径 (m)	3.8m			10.2m			18m		
	オフセット			オフセット			オフセット		
	5°	20°	40°	5°	20°	40°	5°	20°	40°
3.0									
3.5									
4.0									
4.5									
5.0									
6.0									
7.0									
8.0									
9.0									
10.0									
11.0									
12.0		8.8							
14.0		8.3	8.0				3.9		
16.0		7.8	7.6	6.4	6.1		3.9		
18.0	7.6	7.4	7.2	6.3	5.8	5.4	3.9		
20.0	7.1	7.0	6.9	5.9	5.5	5.1	3.9	3.5	
22.0	6.7	6.6	6.5	5.6	5.2	4.9	3.9	3.4	
24.0	6.4	6.3	6.2	5.4	5.0	4.7	3.9	3.3	2.7
26.0	6.1	6.0	5.9	5.1	4.8	4.5	3.9	3.2	2.6
28.0	5.7	5.7	5.6	4.8	4.6	4.3	3.8	3.0	2.5
30.0	5.4	5.4	5.3	4.6	4.4	4.2	3.6	3.0	2.5
32.0	5.1	5.1	5.0	4.4	4.2	4.0	3.5	2.9	2.4
34.0	4.4	4.5	4.6	4.2	4.1	3.9	3.3	2.8	2.4
36.0	3.7	3.8	3.9	4.0	3.9	3.8	3.2	2.7	2.3
38.0	3.1	3.2	3.2	3.5	3.7	3.6	3.1	2.6	2.3
40.0	2.5	2.6	2.6	2.9	3.2	3.5	3.0	2.6	2.3
44.0	1.5	1.6	1.6	1.9	2.2	2.4	2.4	2.5	2.2
48.0				1.1	1.3	1.5	1.6	2.0	2.1
52.0							0.9	1.2	1.6
56.0									0.8
θ(°)	40~77.5	41~82.7	41~82.7	41~80.5	43~82.7	45~82.7	44~82.7	47~82.7	44~82.7
標準フック	22t			7.3t					
フック質量	375kg			300kg					
標準巻掛本数	2			1					

注) カウンタウエイト28t、アウトリガ張出幅7.5m

■B性能

60.0mブーム+バイフォールドパワーテルトジブ

ジブ長さ 作業半径 (m)	3.8m			10.2m			18m		
	オフセット			オフセット			オフセット		
	5°	20°	40°	5°	20°	40°	5°	20°	40°
3.0									
3.5									
4.0									
4.5									
5.0									
6.0									
7.0									
8.0									
9.0									
10.0									
11.0									
12.0									
14.0									
16.0									
18.0									
20.0									
22.0									
24.0									
26.0									
28.0									
30.0									
32.0									
34.0									
36.0									
38.0									
40.0									
44.0									
48.0									
52.0									
56.0									
θ(°)	44~77.5	45~82.7	45~82.7	45~82.7	45~82.7	45~82.7	44~82.7	47~82.7	44~82.7
標準フック	22t			7.3t					
フック質量	375kg			300kg					
標準巻掛本数	2			1					

注) カウンタウエイト28t、アウトリガ張出幅7.5m

■C性能

12.8mブーム+パイフォルドパワーチルトジブ

単位:t

ジブ長さ 作業半径 (m)	3.8m			10.2m			18m		
	オフセット			オフセット			オフセット		
	5°	20°	40°	5°	20°	40°	5°	20°	40°
3.0	40.0	32.7							
3.5	40.0	31.3	25.2				7.8		
4.0	40.0	30.0	24.5	14.6			7.8		
4.5	38.9	28.9	23.8	14.6			7.8		
5.0	36.6	27.8	23.2	14.6	14.1		7.8		
6.0	33.3	26.0	22.2	14.6	13.0		7.8		
7.0	30.4	24.4	21.3	14.6	12.1		7.5		
8.0	28.0	23.1	20.5	14.6	11.3	9.1	7.1		
9.0	26.0	22.0	19.9	13.8	10.6	8.7	6.7	5.2	
10.0	24.3	21.0	19.5	12.6	10.0	8.4	6.3	5.0	
11.0	22.9	20.2	19.2	11.4	9.4	8.0	6.0	4.7	
12.0	21.6	19.6		10.4	9.0	7.8	5.7	4.5	
14.0	20.0			8.9	8.2	7.3	5.1	4.1	3.5
16.0				7.8	7.6	7.0	4.6	3.6	3.3
18.0				6.9	7.1		4.2	3.5	3.1
20.0				6.1			3.9	3.3	3.0
22.0							3.5	3.1	2.9
24.0							3.3	3.0	2.8
26.0							3.1	2.9	
28.0							2.9		
30.0									
32.0									
34.0									
36.0									
38.0									
40.0									
44.0									
48.0									
52.0									
θ (°)	12~77.5	35~82.7	43~82.7	15~80.5	35~82.7	49~82.7	12~82.7	33~82.7	48~82.7
標準フック	50t			22t					
フック質量	600kg			375kg					
標準巻掛本数	6			2					

注) カウンタウエイト25t、アウトリガ張出幅7.5m

■C性能

25.8mブーム+パイフォルドパワーチルトジブ

単位:t

ジブ長さ 作業半径 (m)	3.8m			10.2m			18m		
	オフセット			オフセット			オフセット		
	5°	20°	40°	5°	20°	40°	5°	20°	40°
3.0									
3.5									
4.0									
4.5			34.4						
5.0			33.5					7.4	
6.0			31.9	25.0				7.4	
7.0	35.0	30.4	24.2	14.6	14.6			7.4	
8.0	35.0	29.1	23.5	14.6	13.9			7.4	
9.0	35.0	27.9	22.9	14.6	13.2			7.4	
10.0	34.3	26.8	22.3	14.6	12.6	9.3	7.1		
11.0	31.3	25.9	21.8	14.6	12.0	9.0	6.9		
12.0	27.0	25.0	21.3	14.6	11.5	8.8	6.6	4.8	
14.0	20.9	21.2	20.5	14.6	10.6	8.3	6.1	4.4	
16.0	16.6	16.8	17.0	13.4	9.6	7.9	5.7	4.2	3.4
18.0	13.4	13.6	13.7	12.3	9.2	7.6	5.3	3.9	3.2
20.0	11.0	11.2	11.3	11.1	8.6	7.3	4.9	3.7	3.1
22.0	9.1	9.2	9.3	9.9	8.1	7.1	4.6	3.5	3.0
24.0	7.6	7.7		8.8	7.8	6.9	4.3	3.3	2.9
26.0	6.3			7.5	7.4	6.8	4.0	3.2	2.8
28.0				6.3	6.6		3.8	3.1	2.7
30.0				5.3	5.6		3.6	3.0	2.7
32.0				4.5	4.6		3.4	2.9	2.6
34.0							3.3	2.8	2.6
36.0							3.2	2.8	
38.0							3.0	2.7	
40.0							2.9		
44.0									
48.0									
52.0									
θ (°)	18~77.5	29~82.7	40~82.7	18~80.5	21~82.7	45~82.7	16~82.7	29~82.7	45~82.7
標準フック	50t			22t					
フック質量	600kg			375kg					
標準巻掛本数	5			2					

注) カウンタウエイト25t、アウトリガ張出幅7.5m

■C性能

34.4mブーム+バイフォルドパワーチルトジブ

単位:t

ジブ長さ 作業半径 (m)	3.8m			10.2m			18m		
	オフセット			オフセット			オフセット		
	5°	20°	40°	5°	20°	40°	5°	20°	40°
3.0									
3.5									
4.0									
4.5									
5.0									
6.0									
7.0		17.8	16.3					5.9	
8.0		16.9	15.6	13.4				5.9	
9.0	17.4	16.2	15.0	13.4	12.1			5.9	
10.0	16.6	15.5	14.4	13.4	11.5			5.9	
11.0	15.9	14.9	13.9	12.9	11.0			5.9	
12.0	15.2	14.3	13.4	12.4	10.6	9.0		5.9	
14.0	14.1	13.3	12.6	11.3	9.8	8.5	5.9	4.3	
16.0	13.2	12.5	11.9	10.4	9.1	8.0	5.7	4.1	
18.0	12.4	11.8	11.3	9.7	8.6	7.6	5.4	3.9	3.2
20.0	11.7	11.2	10.8	9.1	8.1	7.2	5.1	3.7	3.0
22.0	10.2	10.3	10.4	8.5	7.6	6.9	4.8	3.6	2.9
24.0	8.6	8.7	8.8	8.0	7.3	6.6	4.6	3.4	2.9
26.0	7.3	7.4	7.5	7.6	6.9	6.4	4.3	3.3	2.8
28.0	6.2	6.2		6.9	6.7	6.2	4.1	3.1	2.7
30.0	5.2	5.2		5.9	6.2	6.0	3.9	3.0	2.6
32.0	4.3	4.4		5.0	5.3	5.5	3.7	2.9	2.6
34.0	3.6			4.3	4.5	4.7	3.6	2.9	2.5
36.0				3.6	3.8		3.4	2.8	2.5
38.0				3.1	3.2		3.3	2.7	2.5
40.0				2.6	2.7		3.2	2.7	2.5
44.0							2.5	2.6	
48.0							1.8		
52.0									
θ (°)	19~77.5	28~82.7	45~82.7	19~80.5	21~82.7	41~82.7	18~82.7	34~82.7	46~82.7
標準フック	50t			22t			7.3t		
フック質量	600kg			375kg			300kg		
標準巻掛本数	3			2			1		

注) カウンタウエイト25t、アウトリガ張出幅7.5m

■C性能

43.0mブーム+バイフォルドパワーチルトジブ

単位:t

ジブ長さ 作業半径 (m)	3.8m			10.2m			18m		
	オフセット			オフセット			オフセット		
	5°	20°	40°	5°	20°	40°	5°	20°	40°
3.0									
3.5									
4.0									
4.5									
5.0									
6.0									
7.0									
8.0									
9.0			14.6	13.6					
10.0			14.0	13.1					5.5
11.0			13.4	12.6	10.6				5.5
12.0	13.7	12.9	12.2	10.6	9.8				5.5
14.0	12.7	12.1	11.4	10.4	9.2	8.0			5.5
16.0	11.9	11.3	10.8	9.6	8.6	7.6			5.5
18.0	11.2	10.7	10.3	9.2	8.1	7.2			5.4
20.0	10.7	10.2	9.8	8.7	7.7	6.9			5.2
22.0	9.6	9.7	9.4	8.2	7.3	6.6			4.9
24.0	8.0	8.2	8.3	7.7	7.0	6.3			4.7
26.0	6.7	6.8	7.0	7.3	6.7	6.1			4.5
28.0	5.5	5.6	5.7	6.1	6.4	5.9			4.3
30.0	4.5	4.6	4.7	5.1	5.5	5.7			4.1
32.0	3.7	3.8	3.8	4.2	4.6	5.0			3.9
34.0	3.0	3.0	3.1	3.5	3.8	4.2			3.8
36.0	2.3	2.4		2.9	3.2	3.4			3.6
38.0	1.7	1.8		2.3	2.6	2.8			3.1
40.0	1.2	1.2		1.8	2.1	2.2			2.6
44.0				0.9	1.1				1.7
48.0									1.0
52.0									1.3
θ (°)	26~77.5	27~82.7	41~82.7	30~80.5	32~82.7	42~82.7	36~82.7	40~82.7	42~82.7
標準フック	50t			22t			7.3t		
フック質量	600kg			375kg			300kg		
標準巻掛本数	3			2			1		

注) カウンタウエイト25t、アウトリガ張出幅7.5m

■C性能

56.0mブーム+バイフォールドパワーチルトジブ

単位:t

ジブ長さ 作業半径 (m)	3.8m			10.2m			18m		
	オフセット			オフセット			オフセット		
	5°	20°	40°	5°	20°	40°	5°	20°	40°
3.0									
3.5									
4.0									
4.5									
5.0									
6.0									
7.0									
8.0									
9.0									
10.0									
11.0									
12.0		8.8							
14.0		8.3	8.0				3.9		
16.0		7.8	7.6	6.4	6.1		3.9		
18.0	7.6	7.4	7.2	6.3	5.8	5.4	3.9		
20.0	7.1	7.0	6.9	5.9	5.5	5.1	3.9	3.5	
22.0	6.7	6.6	6.5	5.6	5.2	4.9	3.9	3.4	
24.0	6.4	6.3	6.2	5.4	5.0	4.7	3.9	3.3	2.7
26.0	6.1	6.0	5.9	5.1	4.8	4.5	3.9	3.2	2.6
28.0	5.7	5.7	5.6	4.8	4.6	4.3	3.8	3.0	2.5
30.0	5.3	5.4	5.3	4.6	4.4	4.2	3.6	3.0	2.5
32.0	4.4	4.5	4.6	4.4	4.2	4.0	3.5	2.9	2.4
34.0	3.7	3.8	3.8	4.1	4.1	3.9	3.3	2.8	2.4
36.0	3.0	3.1	3.2	3.4	3.7	3.8	3.2	2.7	2.3
38.0	2.5	2.5	2.6	2.8	3.1	3.4	3.1	2.6	2.3
40.0	2.0	2.0	2.1	2.3	2.6	2.9	2.8	2.6	2.3
44.0	1.0	1.1	1.1	1.4	1.7	1.9	1.9	2.3	2.2
48.0					0.9	1.1	1.1	1.6	1.9
52.0								0.8	1.2
θ(°)	40~77.5	41~82.7	41~82.7	46~80.5	43~82.7	45~82.7	48~82.7	47~82.7	50~82.7
標準フック	22t			7.3t					
フック質量	375kg			300kg					
標準巻掛本数	2			1					

注) カウンタウエイト25t、アウトリガ張出幅7.5m

■C性能

60.0mブーム+バイフォールドパワーチルトジブ

ジブ長さ 作業半径 (m)	3.8m			10.2m			18m		
	オフセット			オフセット			オフセット		
	5°	20°	40°	5°	20°	40°	5°	20°	40°
3.0									
3.5									
4.0									
4.5									
5.0									
6.0									
7.0									
8.0									
9.0									
10.0									
11.0									
12.0									
14.0		7.5	7.3						
16.0		7.1	6.9						
18.0	6.9	6.8	6.6						
20.0	6.5	6.4	6.3						
22.0	6.1	6.0	5.9						
24.0	5.8	5.7	5.6						
26.0	5.5	5.4	5.4						
28.0	5.3	5.2	5.1						
30.0	5.0	5.0	4.9						
32.0	4.4	4.5	4.6						
34.0	3.7	3.8	3.8						
36.0	3.0	3.1	3.2						
38.0	2.5	2.5	2.6						
40.0	2.0	2.0	2.1						
44.0	1.0	1.1	1.1						
48.0									
52.0									
θ(°)	44~77.5	45~82.7	45~82.7	49~80.5	46~82.7	48~82.7	51~82.7	50~82.7	53~82.7
標準フック	22t			7.3t					
フック質量	375kg			300kg					
標準巻掛本数	2			1					

注) カウンタウエイト25t、アウトリガ張出幅7.5m

■D性能

12.8mブーム+バイフォールドパワーチルトジブ

単位:t

ジブ長さ 作業半径 (m)	3.8m			10.2m			18m					
	オフセット			オフセット			オフセット					
	5°	20°	40°	5°	20°	40°	5°	20°	40°			
3.0	40.0	32.7							7.8			
3.5	40.0	31.3	25.2									
4.0	40.0	30.0	24.5	14.6					7.8			
4.5	38.9	28.9	23.8	14.6					7.8			
5.0	36.8	27.8	23.2	14.6	14.1				7.8			
6.0	33.3	26.0	22.2	14.6	13.0				7.8			
7.0	30.4	24.4	21.3	14.6	12.1				7.5			
8.0	28.0	23.1	20.5	14.6	11.3	9.1	7.1					
9.0	26.0	22.0	19.9	13.8	10.6	8.7	6.7	5.2				
10.0	24.3	21.0	19.5	12.6	10.0	8.4	6.3	5.0				
11.0	22.9	20.2	19.2	11.4	9.4	8.0	6.0	4.7				
12.0	21.6	19.6		10.4	9.0	7.8	5.7	4.5				
14.0	17.0			8.9	8.2	7.3	5.1	4.1	3.5			
16.0				7.8	7.6	7.0	4.6	3.8	3.3			
18.0				6.9	7.1		4.2	3.5	3.1			
20.0				6.1			3.9	3.3	3.0			
22.0							3.5	3.1	2.9			
24.0							3.3	3.0	2.8			
26.0							3.1	2.9				
28.0							2.9					
30.0												
32.0												
34.0												
36.0												
38.0												
40.0												
44.0												
θ (°)	12~77.5	35~82.7	43~82.7	15~80.5	35~82.7	49~82.7	12~82.7	33~82.7	48~82.7			
標準フック	50t			22t								
フック質量	600kg			375kg								
標準巻掛本数	6			2								

注) カウンタウエイト15t、アウトリガ張出幅7.5m

■D性能

25.8mブーム+バイフォールドパワーチルトジブ

単位:t

ジブ長さ 作業半径 (m)	3.8m			10.2m			18m					
	オフセット			オフセット			オフセット					
	5°	20°	40°	5°	20°	40°	5°	20°	40°			
3.0												
3.5												
4.0												
4.5		34.4										
5.0		33.5							7.4			
6.0		31.9	25.0						7.4			
7.0	35.0	30.4	24.2	14.6	14.6				7.4			
8.0	35.0	29.1	23.5	14.6	13.9				7.4			
9.0	35.0	27.9	22.9	14.6	13.2				7.4			
10.0	29.6	26.8	22.3	14.6	12.6	9.3	7.1					
11.0	25.0	25.5	21.8	14.6	12.0	9.0	6.9					
12.0	21.5	21.9	21.3	14.6	11.5	8.8	6.6	4.8				
14.0	16.3	16.6	16.9	14.6	10.6	8.3	6.1	4.4				
16.0	12.1	12.4	12.7	13.4	9.8	7.9	5.7	4.2	3.4			
18.0	9.1	9.3	9.4	10.5	9.2	7.6	5.3	3.9	3.2			
20.0	6.9	7.0	7.1	8.2	8.6	7.3	4.9	3.7	3.1			
22.0	5.2	5.3	5.3	6.5	7.1	7.1	4.6	3.5	3.0			
24.0	3.9	4.0		5.2	5.6	6.1	4.3	3.3	2.9			
26.0	2.8			4.1	4.5	4.8	4.0	3.2	2.8			
28.0				3.2	3.5		3.8	3.1	2.7			
30.0				2.5	2.7		3.5	3.0	2.7			
32.0				1.8	2.0		2.9	2.9	2.6			
34.0							2.3	2.7	2.6			
36.0							1.8	2.1				
38.0							1.4	1.6				
40.0							1.0					
44.0												
θ (°)	18~77.5	29~82.7	40~82.7	18~80.5	21~82.7	45~82.7	16~82.7	29~82.7	45~82.7			
標準フック	50t			22t								
フック質量	600kg			375kg								
標準巻掛本数	5			2								

注) カウンタウエイト15t、アウトリガ張出幅7.5m

■D性能

34.4mブーム+バイフォールドパワーチルトジブ

単位:t

ジブ長さ 作業半径 (m)	3.8m			10.2m			18m		
	オフセット			オフセット			オフセット		
	5°	20°	40°	5°	20°	40°	5°	20°	40°
3.0									
3.5									
4.0									
4.5									
5.0									
6.0									
7.0		17.8	16.3				5.9		
8.0		16.9	15.6	13.4			5.9		
9.0	17.4	16.2	15.0	13.4	12.1		5.9		
10.0	16.6	15.5	14.4	13.4	11.5		5.9		
11.0	15.9	14.9	13.9	12.9	11.0		5.9		
12.0	15.2	14.3	13.4	12.4	10.6	9.0	5.9		
14.0	14.1	13.3	12.6	11.3	9.8	8.5	5.9	4.3	
16.0	13.2	12.5	11.9	10.4	9.1	8.0	5.7	4.1	
18.0	10.4	10.6	10.8	9.7	8.6	7.6	5.4	3.9	3.2
20.0	8.1	8.3	8.5	8.8	8.1	7.2	5.1	3.7	3.0
22.0	6.4	6.5	6.7	7.1	7.6	6.9	4.8	3.6	2.9
24.0	5.0	5.1	5.2	5.7	6.2	6.6	4.6	3.4	2.9
26.0	3.9	4.0	4.1	4.6	5.1	5.5	4.3	3.3	2.8
28.0	3.0	3.1		3.7	4.1	4.5	4.1	3.1	2.7
30.0	2.3	2.4		3.0	3.3	3.6	3.9	3.0	2.6
32.0	1.7	1.7		2.3	2.6	2.8	3.2	2.9	2.6
34.0	1.1			1.8	2.0	2.2	2.6	2.9	2.5
36.0				1.3	1.5		2.1	2.5	2.5
38.0				0.9	1.1		1.7	2.1	2.4
40.0							1.3	1.6	1.9
44.0								0.9	
θ (°)	19~77.5	28~82.7	45~82.7	26~80.5	28~82.7	41~82.7	38~82.7	34~82.7	46~82.7
標準フック	50t			22t			7.3t		
フック質量	600kg			375kg			300kg		
標準巻掛本数	3			2			1		

注) カウンタウエイト15t、アウトリガ張出幅7.5m

■D性能

43.0mブーム+バイフォールドパワーチルトジブ

ジブ長さ 作業半径 (m)	3.8m			5.0m	
	オフセット			オフセット	
	5°	20°	40°	5°	20°
3.0					
3.5					
4.0					
4.5					
5.0					
6.0					
7.0					
8.0					
9.0			14.6	13.6	
10.0			14.0	13.1	
11.0			13.4	12.6	
12.0		13.7	12.9	12.2	
14.0		12.7	12.1	11.4	
16.0		11.9	11.3	10.8	
18.0		9.6	9.9	10.2	
20.0		7.4	7.6	7.8	
22.0		5.7	5.9	6.0	
24.0		4.3	4.5	4.6	
26.0		3.3	3.4	3.5	
28.0		2.4	2.5	2.6	
30.0		1.7	1.8	1.8	
32.0		1.0	1.1	1.2	
34.0					
36.0					
38.0					
40.0					
44.0					
θ (°)	44~77.5	45~82.7	45~82.7	48~82.7	
標準フック	50t				
フック質量	600kg				
標準巻掛本数	3				

注) カウンタウエイト15t、アウトリガ張出幅7.5m

■D性能

56.0mブーム+バイフォールドパワーテルトジブ

単位:t

ジブ長さ 作業半径 (m)	3.8m			10.2m			18m		
	オフセット			オフセット			オフセット		
	5°	20°	40°	5°	20°	40°	5°	20°	40°
3.0									
3.5									
4.0									
4.5									
5.0									
6.0									
7.0									
8.0									
9.0									
10.0									
11.0									
12.0		8.8							
14.0		8.3	8.0				3.9		
16.0		7.8	7.6	6.4	6.1		3.9		
18.0	7.6	7.4	7.2	6.3	5.8	5.4	3.9		
20.0	7.1	7.0	6.9	5.9	5.5	5.1	3.9	3.5	
22.0	6.5	6.6	6.5	5.6	5.2	4.9	3.9	3.4	
24.0	5.1	5.3	5.5	5.4	5.0	4.7	3.9	3.3	2.7
26.0	4.0	4.2	4.3	4.4	4.8	4.5	3.9	3.2	2.6
28.0	3.1	3.3	3.4	3.5	4.0	4.3	3.8	3.0	2.5
30.0	2.4	2.5	2.6	2.8	3.2	3.7	3.3	3.0	2.5
32.0	1.8	1.9	1.9	2.1	2.5	2.9	2.6	2.9	2.4
34.0	1.2	1.3	1.4	1.6	1.9	2.3	2.0	2.7	2.4
36.0		0.8	0.9	1.1	1.4	1.7	1.5	2.1	2.3
38.0					1.0	1.3	1.1	1.6	2.2
40.0						0.8		1.2	1.7
44.0									0.9
θ (°)	54~77.5	52~82.7	52~82.7	55~80.5	55~82.7	55~82.7	58~82.7	59~82.7	59~82.7
標準フック	22t			7.3t					
フック質量	375kg			300kg					
標準巻掛本数	2			1					

注) カウンタウエイト15t、アウトリガ張出幅7.5m

■D性能

60.0mブーム+バイフォールドパワーテルトジブ

単位:t

ジブ長さ 作業半径 (m)	3.8m			10.2m			18m		
	オフセット			オフセット			オフセット		
	5°	20°	40°	5°	20°	40°	5°	20°	40°
3.0									
3.5									
4.0									
4.5									
5.0									
6.0									
7.0									
8.0									
9.0									
10.0									
11.0									
12.0									
14.0				7.5	7.3				3.6
16.0				7.1	6.9	5.7	5.6		3.6
18.0	6.9	6.8	6.6	6.6	5.7	5.3			3.6
20.0	6.5	6.4	6.3	6.4	5.4	5.1	4.7		3.6
22.0	6.1	6.0	5.9	6.1	5.1	4.8	4.5	3.6	3.3
24.0	5.1	5.3	5.5	5.4	4.9	4.6	4.3	3.6	3.2
26.0	4.0	4.2	4.3	4.4	4.4	4.4	4.2	3.6	3.1
28.0	3.1	3.3	3.4	3.5	4.0	4.0	3.5	3.0	2.5
30.0	2.4	2.5	2.6	2.7	3.2	3.2	3.6	3.2	2.9
32.0	1.7	1.8	1.9	2.1	2.5	2.9	2.5	2.8	2.4
34.0	1.2	1.3	1.4	1.5	1.9	2.3	2.0	2.6	2.3
36.0		0.8	0.9	1.1	1.4	1.7	1.5	2.1	2.3
38.0					0.9	1.2			1.6
40.0									1.2
44.0									0.9
θ (°)	56~77.5	54~82.7	55~82.7	58~80.5	57~82.7	59~82.7	62~82.7	61~82.7	64~82.7
標準フック	22t			7.3t					
フック質量	375kg			300kg					
標準巻掛本数	2			1					

注) カウンタウエイト15t、アウトリガ張出幅7.5m



■E性能

12.8mブーム+パイフォールドパワーチルトジブ

単位:t

ジブ長さ 作業半径 (m)	3.8m			10.2m			18m		
	オフセット			オフセット			オフセット		
	5°	20°	40°	5°	20°	40°	5°	20°	40°
3.0	40.0	32.7							
3.5	40.0	31.3	25.2				7.8		
4.0	40.0	30.0	24.5	14.6			7.8		
4.5	38.9	28.9	23.8	14.6			7.8		
5.0	36.8	27.8	23.2	14.6	14.1		7.8		
6.0	33.3	26.0	22.2	14.6	13.0		7.8		
7.0	30.4	24.4	21.3	14.6	12.1		7.5		
8.0	28.0	23.1	20.5	14.6	11.3	9.1	7.1		
9.0	26.0	22.0	19.9	13.8	10.6	8.7	6.7	5.2	
10.0	24.1	21.0	19.5	12.6	10.0	8.4	6.3	5.0	
11.0	19.3	19.7	19.2	11.4	9.4	8.0	6.0	4.7	
12.0	15.3	15.6		10.4	9.0	7.8	5.7	4.5	
14.0	10.1			8.9	8.2	7.3	5.1	4.1	3.5
16.0				7.8	7.6	7.0	4.6	3.8	3.3
18.0				6.9	7.1		4.2	3.5	3.1
20.0				5.6			3.9	3.3	3.0
22.0							3.5	3.1	2.9
24.0							3.3	3.0	2.8
26.0							3.1	2.9	
28.0							2.9		
30.0									
32.0									
34.0									
36.0									
θ (°)	12~77.5	35~82.7	43~82.7	15~80.5	35~82.7	49~82.7	12~82.7	33~82.7	48~82.7
標準フック	50t			22t					
フック質量	600kg			375kg					
標準巻掛本数	6			2					

注) カウンタウエイト6t、アウトリガ張出幅7.5m

■E性能

25.8mブーム+パイフォールドパワーチルトジブ

ジブ長さ 作業半径 (m)	3.8m								
	オフセット								
	5°	20°	40°						
3.0									
3.5									
4.0									
4.5									
5.0									
6.0									
7.0									
8.0									
9.0									
10.0									
11.0									
12.0									
14.0									
16.0									
18.0									
20.0									
22.0									
24.0									
26.0									
28.0									
30.0									
32.0									
34.0									
36.0									
θ (°)	36~77.5	37~82.7	40~82.7	39					
標準フック	50t								
フック質量	600kg								
標準巻掛本数	5								

注) カウンタウエイト6t、アウトリガ張出幅7.5m

■E性能

34.4mブーム+バイフォールドパワーテルトジブ

単位:t

ジブ長さ 作業半径 (m)	3.8m			10.2m			18m		
	オフセット			オフセット			オフセット		
	5°	20°	40°	5°	20°	40°	5°	20°	40°
3.0									
3.5									
4.0									
4.5									
5.0									
6.0									
7.0		17.8	16.3					5.9	
8.0		16.9	15.6	13.4				5.9	
9.0	17.4	16.2	15.0	13.4	12.1			5.9	
10.0	16.6	15.5	14.4	13.4	11.5			5.9	
11.0	15.9	14.9	13.9	12.9	11.0			5.9	
12.0	15.2	14.3	13.4	12.4	10.6	9.0		5.9	
14.0	10.8	11.2	11.6	11.3	9.8	8.5	5.9	4.3	
16.0	7.6	7.9	8.2	8.4	9.1	8.0	5.7	4.1	
18.0	5.4	5.6	5.8	6.2	7.0	7.6	5.4	3.9	3.2
20.0	3.8	4.0	4.1	4.5	5.2	6.0	5.1	3.7	3.0
22.0	2.6	2.7	2.9	3.3	3.9	4.5	4.4	3.6	2.9
24.0	1.6	1.8	1.9	2.4	2.9	3.4	3.4	3.4	2.9
26.0	0.9	1.0	1.1	1.6	2.0	2.5	2.6	3.3	2.8
28.0				1.0	1.3	1.7	1.9	2.6	2.7
30.0						1.0	1.3	1.9	2.8
32.0							0.8	1.4	2.0
34.0								0.9	1.4
36.0									0.9
θ (°)	44~77.5	44~82.7	45~82.7	48~80.5	51~82.7	50~82.7	51~82.7	52~82.7	53~82.7
標準フック	50t			22t			7.3t		
フック質量	600kg			375kg			300kg		
標準巻掛本数	3			2			1		

注) カウンタウエイト6t、アウトリガ張出幅7.5m

■E性能

43.0mブーム+バイフォールドパワーテルトジブ

単位:t

ジブ長さ 作業半径 (m)	3.8m			10.2m			18m		
	オフセット			オフセット			オフセット		
	5°	20°	40°	5°	20°	40°	5°	20°	40°
3.0									
3.5									
4.0									
4.5									
5.0									
6.0									
7.0									
8.0									
9.0									
10.0				14.6	13.6				
11.0				14.0	13.1				5.5
12.0				13.4	12.6	10.6			5.5
14.0	13.7	12.9	12.2	10.6	9.8				5.5
16.0	10.0	10.4	10.8	10.4	9.2	8.0			5.5
18.0	6.8	7.1	7.5	7.4	6.6	7.6	5.5	4.1	
20.0	4.6	4.9	5.2	5.2	6.2	7.2	5.4	3.9	
22.0	3.1	3.3	3.5	3.7	4.5	5.4	4.8	3.7	3.0
24.0	1.9	2.1	2.3	2.5	3.2	3.9	3.5	3.6	2.9
26.0	1.0	1.1	1.3	1.5	2.2	2.8	2.6	3.4	2.8
28.0				0.8	1.3	1.9	1.8	2.7	2.7
30.0						1.1	1.1	1.9	2.7
32.0								1.3	2.1
34.0									1.5
36.0									0.9
θ (°)	57~77.5	58~82.7	58~82.7	58~80.5	61~82.7	61~82.7	62~82.7	63~82.7	63~82.7
標準フック	50t			22t			7.3t		
フック質量	600kg			375kg			300kg		
標準巻掛本数	3			2			1		

注) カウンタウエイト6t、アウトリガ張出幅7.5m

■E性能

56.0mブーム+バイフォールドパワーチルトジブ

単位:t

ジブ長さ 作業半径 (m)	3.8m			10.2m			18m		
	オフセット			オフセット			オフセット		
	5°	20°	40°	5°	20°	40°	5°	20°	40°
3.0									
3.5									
4.0									
4.5									
5.0									
6.0									
7.0									
8.0									
9.0									
10.0									
11.0									
12.0		8.8							
14.0		8.3	8.0				3.9		
16.0		7.8	7.6	6.4	6.1		3.9		
18.0	5.5	5.8	6.1	6.0	5.8	5.4	3.9		
20.0	3.9	4.2	4.4	4.4	5.1	5.1	3.9	3.5	
22.0	2.7	2.9	3.1	3.1	3.8	4.6	3.7	3.4	
24.0	1.8	1.9	2.1	2.2	2.8	3.4	2.7	3.3	2.7
26.0	1.0	1.1	1.3	1.4	1.9	2.5	1.9	2.8	2.6
28.0				0.8	1.2	1.7	1.3	2.1	2.5
30.0						1.1		1.5	2.3
32.0								0.9	1.7
34.0									1.1
36.0									
θ(°)	63~77.5	63~82.7	64~82.7	63~80.5	65~82.7	66~82.7	67~82.7	67~82.7	68~82.7
標準フック	22t			7.3t					
フック質量	375kg			300kg					
標準巻掛本数	2			1					

注) カウンタウエイト6t、アウトリガ張出幅7.5m

■E性能

60.0mブーム+バイフォールドパワーチルトジブ

ジブ長さ 作業半径 (m)	3.8m			10.2m			18m			25.5m		
	オフセット			オフセット			オフセット			オフセット		
	5°	20°	40°	5°	20°	40°	5°	20°	40°	5°	20°	40°
3.0												
3.5												
4.0												
4.5												
5.0												
6.0												
7.0												
8.0												
9.0												
10.0												
11.0												
12.0												
14.0												
16.0												
18.0	5.5	5.8	6.1	6.0	5.8	5.4	3.9					
20.0	3.9	4.2	4.4	4.4	5.1	5.1	3.9	3.5				
22.0	2.7	2.9	3.1	3.1	3.8	4.6	3.7	3.4				
24.0	1.8	1.9	2.1	2.2	2.8	3.4	2.7	3.3	2.7			
26.0	1.0	1.1	1.3	1.4	1.9	2.5	1.9	2.8	2.6			
28.0				0.8	1.2	1.7	1.3	2.1	2.5			
30.0						1.1		1.5	2.3			
32.0								0.9	1.7			
34.0									1.1			
36.0												
θ(°)	65~77.5	65~82.7	66~82.7	65~80.5	67~82.7	68~82.7	69~82.7	69~82.7	70~82.7	71~82.7	72~82.7	73~82.7
標準フック	22t			7.3t						10.5t		
フック質量	375kg			300kg						450kg		
標準巻掛本数	2			1						1		

注) カウンタウエイト6t、アウトリガ張出幅7.5m

■F性能

12.8mブーム+パイフールドパワーチルトジブ

単位:t

ジブ長さ 作業半径 (m)	3.8m			10.2m			18m		
	オフセット			オフセット			オフセット		
	5°	20°	40°	5°	20°	40°	5°	20°	40°
3.0	40.0	32.7							
3.5	40.0	31.3	25.2				7.8		
4.0	40.0	30.0	24.5	14.6			7.8		
4.5	38.9	28.9	23.8	14.6			7.8		
5.0	36.8	27.8	23.2	14.6	14.1		7.8		
6.0	33.3	26.0	22.2	14.6	13.0		7.8		
7.0	30.4	24.4	21.3	14.6	12.1		7.5		
8.0	28.0	23.1	20.5	14.6	11.3	9.1	7.1		
9.0	26.0	22.0	19.9	13.8	10.6	8.7	6.7	5.2	
10.0	24.3	21.0	19.5	12.6	10.0	8.4	6.3	5.0	
11.0	22.9	20.2	19.2	11.4	9.4	8.0	6.0	4.7	
12.0	21.6	19.6		10.4	9.0	7.8	5.7	4.5	
14.0	20.0			8.9	8.2	7.3	5.1	4.1	3.5
16.0				7.8	7.6	7.0	4.6	3.8	3.3
18.0				6.9	7.1		4.2	3.5	3.1
20.0				6.1			3.9	3.3	3.0
22.0							3.5	3.1	2.9
24.0							3.3	3.0	2.8
26.0							3.1	2.9	
28.0							2.9		
30.0									
32.0									
34.0									
36.0									
38.0									
40.0									
44.0									
48.0									
52.0									
56.0									
θ(°)	12~77.5	35~82.7	43~82.7	15~80.5	35~82.7	49~82.7	12~82.7	33~82.7	48~82.7
標準フック	50t			22t					
フック質量	600kg			375kg					
標準巻掛本数	6			2					

注) カウンタウエイト40t、アウトリガ張出幅6.2m

■F性能

25.8mブーム+パイフールドパワーチルトジブ

ジブ長さ 作業半径 (m)	3.8m								
	オフセット								
	5°	20°	40°						
3.0									
3.5									
4.0									
4.5			34.4						
5.0			33.5						
6.0			31.9	25.0					
7.0	35.0	30.4	24.2						
8.0	35.0	29.1	23.5						
9.0	35.0	27.9	22.9						
10.0	34.3	26.8	22.3						
11.0	32.5	25.9	21.8						
12.0	30.4	25.0	21.3						
14.0	24.4	23.4	20.5						
16.0	19.5	19.8	19.9						
18.0	16.0	16.2	16.3						
20.0	13.3	13.4	13.5						
22.0	11.2	11.3	11.3						
24.0	9.5	9.5							
26.0	8.1								
28.0									
30.0									
32.0									
34.0									
36.0									
38.0									
40.0									
44.0									
48.0									
52.0									
56.0									
θ(°)	18~77.5	29~82.7	40~82.7	18					
標準フック	50t								
フック質量	600kg								
標準巻掛本数	5								

注) カウンタウエイト40t、アウトリガ張出幅6.2m

■F性能

34.4mブーム+パイフールドパワーチルトジブ

単位:t

ジブ長さ 作業半径 (m)	3.8m			10.2m			18m		
	オフセット			オフセット			オフセット		
	5°	20°	40°	5°	20°	40°	5°	20°	40°
3.0									
3.5									
4.0									
4.5									
5.0									
6.0									
7.0		17.8	16.3				5.9		
8.0		16.9	15.6	13.4			5.9		
9.0	17.4	16.2	15.0	13.4	12.1		5.9		
10.0	16.6	15.5	14.4	13.4	11.5		5.9		
11.0	15.9	14.9	13.9	12.9	11.0		5.9		
12.0	15.2	14.3	13.4	12.4	10.6	9.0	5.9		
14.0	14.1	13.3	12.6	11.3	9.8	8.5	5.9	4.3	
16.0	13.2	12.5	11.9	10.4	9.1	8.0	5.7	4.1	
18.0	12.4	11.8	11.3	9.7	8.6	7.6	5.4	3.9	3.2
20.0	11.7	11.2	10.8	9.1	8.1	7.2	5.1	3.7	3.0
22.0	11.2	10.8	10.4	8.5	7.6	6.9	4.8	3.6	2.9
24.0	10.4	10.3	10.1	8.0	7.3	6.6	4.6	3.4	2.9
26.0	9.0	9.1	9.2	7.6	6.9	6.4	4.3	3.3	2.8
28.0	7.8	7.9		7.3	6.7	6.2	4.1	3.1	2.7
30.0	6.8	6.8		7.0	6.4	6.0	3.9	3.0	2.6
32.0	5.9	5.9		6.5	6.2	5.8	3.7	2.9	2.6
34.0	5.0			5.8	6.0	5.7	3.6	2.9	2.5
36.0				5.0	5.2		3.4	2.8	2.5
38.0				4.4	4.5		3.3	2.7	2.5
40.0				3.8	3.9		3.2	2.7	2.5
44.0							3.0	2.6	
48.0							2.7		
52.0									
56.0									
θ (°)	19~77.5	28~82.7	45~82.7	19~80.5	21~82.7	41~82.7	30~82.7	34~82.7	46~82.7
標準フック	50t			22t			7.3t		
フック質量	600kg			375kg			300kg		
標準巻掛本数	3			2			1		

注) カウンタウエイト40t、アウトリガ張出幅6.2m

■F性能

43.0mブーム+パイフールドパワーチルトジブ

ジブ長さ 作業半径 (m)	3.8m			10.2m			18m			26m		
	オフセット			オフセット			オフセット			オフセット		
	5°	20°	40°	5°	20°	40°	5°	20°	40°	5°	20°	40°
3.0												
3.5												
4.0												
4.5												
5.0												
6.0												
7.0												
8.0												
9.0									14.6	13.6		
10.0									14.0	13.1		
11.0									13.4	12.6		
12.0									13.7	12.9	12.2	
14.0									12.7	12.1	11.4	
16.0									11.9	11.3	10.8	
18.0									11.2	10.7	10.3	
20.0									10.7	10.2	9.8	
22.0									10.1	9.8	9.4	
24.0									9.5	9.4	9.1	
26.0									8.4	8.5	8.6	
28.0									7.2	7.3	7.4	
30.0									6.1	6.2	6.3	
32.0									5.1	5.2	5.3	
34.0									4.3	4.4	4.4	
36.0									3.5	3.6		
38.0									2.9	2.9		
40.0									2.3	2.3		
44.0									1.3			
48.0												
52.0												
56.0												
θ (°)	40~77.5	41~82.7	41~82.7	41~82.7	41~82.7	41~82.7	30~82.7	34~82.7	46~82.7	46~82.7	46~82.7	45~
標準フック	50t			22t			7.3t			50t		
フック質量	600kg			375kg			300kg			600kg		
標準巻掛本数	3			2			1			3		

注) カウンタウエイト40t、アウトリガ張出幅6.2m

■F性能

56.0mブーム+パイフールドパワーテルトジブ

単位:t

ジブ長さ 作業半径 (m)	3.8m			10.2m			18m		
	オフセット			オフセット			オフセット		
	5°	20°	40°	5°	20°	40°	5°	20°	40°
3.0									
3.5									
4.0									
4.5									
5.0									
6.0									
7.0									
8.0									
9.0									
10.0									
11.0									
12.0		8.8							
14.0		8.3	8.0				3.9		
16.0		7.8	7.6	6.4	6.1		3.9		
18.0	7.6	7.4	7.2	6.3	5.8	5.4	3.9		
20.0	7.1	7.0	6.9	5.9	5.5	5.1	3.9	3.5	
22.0	6.7	6.6	6.5	5.6	5.2	4.9	3.9	3.4	
24.0	6.4	6.3	6.2	5.4	5.0	4.7	3.9	3.3	2.7
26.0	6.1	6.0	5.9	5.1	4.8	4.5	3.9	3.2	2.6
28.0	5.7	5.7	5.6	4.8	4.6	4.3	3.8	3.0	2.5
30.0	5.4	5.4	5.3	4.6	4.4	4.2	3.6	3.0	2.5
32.0	5.1	5.1	5.0	4.4	4.2	4.0	3.5	2.9	2.4
34.0	4.9	4.8	4.8	4.2	4.1	3.9	3.3	2.8	2.4
36.0	4.3	4.4	4.5	4.0	3.9	3.8	3.2	2.7	2.3
38.0	3.6	3.7	3.8	3.9	3.7	3.6	3.1	2.6	2.3
40.0	3.0	3.1	3.2	3.5	3.6	3.5	3.0	2.6	2.3
44.0	2.0	2.1	2.1	2.4	2.7	2.9	2.8	2.5	2.2
48.0	1.2	1.2		1.6	1.8	2.0	2.0	2.4	2.1
52.0				0.9	1.0		1.3	1.7	2.0
56.0								1.0	1.2
θ(°)	51~77.5	52~82.7	49~82.7	53~80.5	53~82.7	55~82.7	56~82.7	56~82.7	59~82.7
標準フック	22t			7.3t					
フック質量	375kg			300kg					
標準巻掛本数	2			1					

注) カウンタウエイト40t、アウトリガ張出幅6.2m

■F性能

60.0mブーム+パイフールドパワーテルトジブ

ジブ長さ 作業半径 (m)	3.8m			10.2m			18m		
	オフセット			オフセット			オフセット		
	5°	20°	40°	5°	20°	40°	5°	20°	40°
3.0									
3.5									
4.0									
4.5									
5.0									
6.0									
7.0									
8.0									
9.0									
10.0									
11.0									
12.0									
14.0									
16.0									
18.0									
20.0									
22.0									
24.0									
26.0									
28.0									
30.0									
32.0									
34.0									
36.0									
38.0									
40.0									
44.0									
48.0									
52.0									
56.0									
θ(°)	54~77.5	54~82.7	53~82.7	56~82.7	56~82.7	59~82.7	56~82.7	56~82.7	59~82.7
標準フック	22t			7.3t					
フック質量	375kg			300kg					
標準巻掛本数	2			1					

注) カウンタウエイト40t、アウトリガ張出幅6.2m

■G性能

12.8mブーム+バイフォールドパワーチルトジブ

単位:t

ジブ長さ (m)	3.8m			10.2m			18m		
	オフセット			オフセット			オフセット		
	5°	20°	40°	5°	20°	40°	5°	20°	40°
3.0	40.0	32.7							
3.5	40.0	31.3	25.2				7.8		
4.0	40.0	30.0	24.5	14.6			7.8		
4.5	38.9	28.9	23.8	14.6			7.8		
5.0	36.8	27.8	23.2	14.6	14.1		7.8		
6.0	33.3	26.0	22.2	14.6	13.0		7.8		
7.0	30.4	24.4	21.3	14.6	12.1		7.5		
8.0	28.0	23.1	20.5	14.6	11.3	9.1	7.1		
9.0	26.0	22.0	19.9	13.8	10.6	8.7	6.7	5.2	
10.0	24.3	21.0	19.5	12.6	10.0	8.4	6.3	5.0	
11.0	22.9	20.2	19.2	11.4	9.4	8.0	6.0	4.7	
12.0	21.6	19.6		10.4	9.0	7.8	5.7	4.5	
14.0	19.4			8.9	8.2	7.3	5.1	4.1	3.5
16.0				7.8	7.6	7.0	4.6	3.8	3.3
18.0				6.9	7.1		4.2	3.5	3.1
20.0				6.1			3.9	3.3	3.0
22.0							3.5	3.1	2.9
24.0							3.3	3.0	2.8
26.0							3.1	2.9	
28.0							2.9		
30.0									
32.0									
34.0									
36.0									
38.0									
40.0									
44.0									
48.0									
θ (°)	12~77.5	35~82.7	43~82.7	15~80.5	35~82.7	49~82.7	12~82.7	33~82.7	48~82.7
標準フック	50t			22t					
フック質量	600kg			375kg					
標準巻掛本数	6			2					

注) カウンタウエイト28t、アウトリガ張出幅6.2m

■G性能

25.8mブーム+バイフォールドパワーチルトジブ

ジブ長さ (m)	3.8m								
	オフセット								
	5°	20°	40°						
3.0									
3.5									
4.0									
4.5			34.4						
5.0			33.5						
6.0			31.9	25.0					
7.0	35.0	30.4	24.2						
8.0	35.0	29.1	23.5						
9.0	35.0	27.9	22.9						
10.0	33.6	26.8	22.3						
11.0	28.5	25.9	21.8						
12.0	24.5	24.9	21.3						
14.0	18.7	19.0	19.3						
16.0	14.8	15.0	15.2						
18.0	11.9	12.0	12.2						
20.0	9.7	9.8	9.9						
22.0	7.9	8.0	8.1						
24.0	6.5	6.6							
26.0	5.2								
28.0									
30.0									
32.0									
34.0									
36.0									
38.0									
40.0									
44.0									
48.0									
θ (°)	18~77.5	29~82.7	40~82.7	18					
標準フック	50t								
フック質量	600kg								
標準巻掛本数	5								

注) カウンタウエイト28t、アウトリガ張出幅6.2m

■G性能

34.4mブーム+バイフォールドパワーチルトジブ

単位:t

ジブ長さ (m)	3.8m			10.2m			18m		
	オフセット			オフセット			オフセット		
	5°	20°	40°	5°	20°	40°	5°	20°	40°
3.0									
3.5									
4.0									
4.5									
5.0									
6.0									
7.0		17.8	16.3				5.9		
8.0		16.9	15.6	13.4			5.9		
9.0	17.4	16.2	15.0	13.4	12.1		5.9		
10.0	16.6	15.5	14.4	13.4	11.5		5.9		
11.0	15.9	14.9	13.9	12.9	11.0		5.9		
12.0	15.2	14.3	13.4	12.4	10.6	9.0	5.9		
14.0	14.1	13.3	12.6	11.3	9.8	8.5	5.9	4.3	
16.0	13.2	12.5	11.9	10.4	9.1	8.0	5.7	4.1	
18.0	12.4	11.8	11.3	9.7	8.6	7.6	5.4	3.9	3.2
20.0	10.7	10.9	10.8	9.1	8.1	7.2	5.1	3.7	3.0
22.0	8.9	9.1	9.2	8.5	7.6	6.9	4.8	3.6	2.9
24.0	7.5	7.6	7.7	8.0	7.3	6.6	4.6	3.4	2.9
26.0	6.3	6.4	6.5	6.9	6.9	6.4	4.3	3.3	2.8
28.0	5.3	5.4		6.0	6.3	6.2	4.1	3.1	2.7
30.0	4.3	4.4		5.1	5.4	5.7	3.9	3.0	2.6
32.0	3.5	3.6		4.3	4.6	4.8	3.7	2.9	2.6
34.0	2.8			3.6	3.8	4.0	3.6	2.9	2.5
36.0				2.9	3.2		3.4	2.8	2.5
38.0				2.4	2.6		3.3	2.7	2.5
40.0				1.9	2.0		2.8	2.7	2.5
44.0							1.9	2.2	
48.0							1.2		
θ (°)	19~77.5	28~82.7	45~82.7	19~80.5	21~82.7	41~82.7	18~82.7	34~82.7	46~82.7
標準フック	50t			22t			7.3t		
フック質量	600kg			375kg			300kg		
標準巻掛本数	3			2			1		

注) カウンタウエイト28t、アウトリガ張出幅6.2m

■G性能

43.0mブーム+バイフォールドパワーチルトジブ

ジブ長さ (m)	3.8m			5°
	オフセット			
	5°	20°	40°	
3.0				
3.5				
4.0				
4.5				
5.0				
6.0				
7.0				
8.0				
9.0		14.6	13.6	
10.0		14.0	13.1	
11.0		13.4	12.6	
12.0	13.7	12.9	12.2	
14.0	12.7	12.1	11.4	
16.0	11.9	11.3	10.8	
18.0	11.2	10.7	10.3	
20.0	10.1	10.2	9.8	
22.0	8.3	8.5	8.6	
24.0	6.9	7.0	7.2	
26.0	5.6	5.8	5.9	
28.0	4.5	4.7	4.8	
30.0	3.6	3.7	3.8	
32.0	2.8	2.9	2.9	
34.0	2.1	2.1	2.2	
36.0	1.5	1.5		
38.0	0.9	1.0		
40.0				
44.0				
48.0				
θ (°)	32~77.5	32~82.7	41~82.7	38~
標準フック	50t			
フック質量	600kg			
標準巻掛本数	3			

注) カウンタウエイト28t、アウトリガ張出幅6.2m



■G性能

56.0mブーム+バイフォールドパワーチルトジブ										単位:t
ジブ長さ 作業半径 (m)	3.8m			10.2m			18m			
	オフセット			オフセット			オフセット			
	5°	20°	40°	5°	20°	40°	5°	20°	40°	
3.0										
3.5										
4.0										
4.5										
5.0										
6.0										
7.0										
8.0										
9.0										
10.0										
11.0										
12.0		8.8								
14.0		8.3	8.0					3.9		
16.0		7.8	7.6	6.4	6.1			3.9		
18.0	7.6	7.4	7.2	6.3	5.8	5.4	3.9			
20.0	7.1	7.0	6.9	5.9	5.5	5.1	3.9	3.5		
22.0	6.7	6.6	6.5	5.6	5.2	4.9	3.9	3.4		
24.0	6.4	6.3	6.2	5.4	5.0	4.7	3.9	3.3	2.7	
26.0	6.1	6.0	5.9	5.1	4.8	4.5	3.9	3.2	2.6	
28.0	5.4	5.5	5.6	4.8	4.6	4.3	3.8	3.0	2.5	
30.0	4.4	4.5	4.6	4.6	4.4	4.2	3.6	3.0	2.5	
32.0	3.6	3.7	3.8	4.0	4.2	4.0	3.5	2.9	2.4	
34.0	2.9	3.0	3.1	3.3	3.7	3.9	3.3	2.8	2.4	
36.0	2.2	2.3	2.4	2.7	3.0	3.4	3.2	2.7	2.3	
38.0	1.7	1.8	1.8	2.1	2.4	2.8	2.6	2.6	2.3	
40.0	1.2	1.3	1.3	1.6	1.9	2.2	2.1	2.6	2.3	
44.0					1.0	1.2	1.2	1.7	2.2	
48.0								0.9	1.3	
θ (°)	46~77.5	46~82.7	47~82.7	51~80.5	48~82.7	50~82.7	52~82.7	51~82.7	54~82.7	
標準フック	22t						7.3t			
フック質量	375kg						300kg			
標準巻掛本数	2						1			

注) カウンタウエイト28t、アウトリガ張出幅6.2m

■G性能

60.0mブーム+バイフォールドパワーチルトジブ										単位:t
ジブ長さ 作業半径 (m)	3.8m			10.2m			18m			
	オフセット			オフセット			オフセット			
	5°	20°	40°	5°	20°	40°	5°	20°	40°	
3.0										
3.5										
4.0										
4.5										
5.0										
6.0										
7.0										
8.0										
9.0										
10.0										
11.0										
12.0										
14.0						7.5	7.3			3.6
16.0						7.1	6.9	5.7	5.6	3.6
18.0						6.9	6.8	6.6	5.7	5.3
20.0						6.5	6.4	6.3	5.4	5.1
22.0						6.1	6.0	5.9	5.1	4.8
24.0						5.8	5.7	5.6	4.9	4.6
26.0						5.5	5.4	5.4	4.7	4.4
28.0						5.3	5.2	5.1	4.4	4.2
30.0						4.4	4.5	4.6	4.2	4.0
32.0						3.6	3.7	3.8	3.9	3.9
34.0						2.8	3.0	3.0	3.2	3.6
36.0						2.2	2.3	2.4	2.6	3.0
38.0						1.7	1.8	1.8	2.0	2.4
40.0						1.2	1.2	1.3	1.5	1.9
44.0									1.0	1.2
48.0										1.1
θ (°)	49~77.5	50~82.7	50~82.7	54~80.5	51~82.7	53~82.7	55~82.7	58~82.7	57~82.7	
標準フック	22t						7.3t			
フック質量	375kg						300kg			
標準巻掛本数	2						1			

注) カウンタウエイト28t、アウトリガ張出幅6.2m

■H性能

12.8mブーム+バイフォールドパワーチルトジブ

単位:t

ジブ長さ (m)	3.8m			10.2m			18m		
	オフセット			オフセット			オフセット		
	5°	20°	40°	5°	20°	40°	5°	20°	40°
3.0	40.0	32.7							
3.5	40.0	31.3	25.2				7.8		
4.0	40.0	30.0	24.5	14.6			7.8		
4.5	38.9	28.9	23.8	14.6			7.8		
5.0	36.8	27.8	23.2	14.6	14.1		7.8		
6.0	33.3	26.0	22.2	14.6	13.0		7.8		
7.0	30.4	24.4	21.3	14.6	12.1		7.5		
8.0	28.0	23.1	20.5	14.6	11.3	9.1	7.1		
9.0	26.0	22.0	19.9	13.8	10.6	8.7	6.7	5.2	
10.0	24.3	21.0	19.5	12.6	10.0	8.4	6.3	5.0	
11.0	22.9	20.2	19.2	11.4	9.4	8.0	6.0	4.7	
12.0	21.6	19.6		10.4	9.0	7.8	5.7	4.5	
14.0	18.0			8.9	8.2	7.3	5.1	4.1	3.5
16.0				7.8	7.6	7.0	4.6	3.8	3.3
18.0				6.9	7.1		4.2	3.5	3.1
20.0				6.1			3.9	3.3	3.0
22.0							3.5	3.1	2.9
24.0							3.3	3.0	2.8
26.0							3.1	2.9	
28.0							2.9		
30.0									
32.0									
34.0									
36.0									
38.0									
40.0									
44.0									
48.0									
θ (°)	12~77.5	35~82.7	43~82.7	15~80.5	35~82.7	49~82.7	12~82.7	33~82.7	48~82.7
標準フック	50t			22t					
フック質量	600kg			375kg					
標準巻掛本数	6			2					

注) カウンタウエイト25t、アウトリガ張出幅6.2m

■H性能

25.8mブーム+バイフォールドパワーチルトジブ

ジブ長さ (m)	3.8m			10.2m			18m		
	オフセット			オフセット			オフセット		
	5°	20°	40°	5°	20°	40°	5°	20°	40°
3.0									
3.5									
4.0									
4.5			34.4						
5.0			33.5						
6.0			31.9	25.0					
7.0	35.0	30.4	24.2						
8.0	35.0	29.1	23.5						
9.0	35.0	27.9	22.9						
10.0	31.3	26.8	22.3						
11.0	26.5	25.9	21.8						
12.0	22.7	23.1	21.3						
14.0	17.3	17.6	17.9						
16.0	13.6	13.8	14.0						
18.0	10.8	11.0	11.1						
20.0	8.7	8.9	9.0						
22.0	7.1	7.2	7.2						
24.0	5.7	5.7							
26.0	4.4								
28.0									
30.0									
32.0									
34.0									
36.0									
38.0									
40.0									
44.0									
48.0									
θ (°)	18~77.5	29~82.7	40~82.7	18~82.7	33~82.7	48~82.7	18~82.7	33~82.7	48~82.7
標準フック	50t			22t					
フック質量	600kg			375kg					
標準巻掛本数	5			2					

注) カウンタウエイト25t、アウトリガ張出幅6.2m

■H性能

34.4mブーム+バイフォールドパワーチルトジブ

単位:t

ジブ長さ (m)	3.8m			10.2m			18m		
	オフセット			オフセット			オフセット		
	5°	20°	40°	5°	20°	40°	5°	20°	40°
3.0									
3.5									
4.0									
4.5									
5.0									
6.0									
7.0		17.8	16.3				5.9		
8.0		16.9	15.6	13.4			5.9		
9.0	17.4	16.2	15.0	13.4	12.1		5.9		
10.0	16.6	15.5	14.4	13.4	11.5		5.9		
11.0	15.9	14.9	13.9	12.9	11.0		5.9		
12.0	15.2	14.3	13.4	12.4	10.6	9.0	5.9		
14.0	14.1	13.3	12.6	11.3	9.8	8.5	5.9	4.3	
16.0	13.2	12.5	11.9	10.4	9.1	8.0	5.7	4.1	
18.0	11.9	11.8	11.3	9.7	8.6	7.6	5.4	3.9	3.2
20.0	9.8	9.9	10.1	9.1	8.1	7.2	5.1	3.7	3.0
22.0	8.1	8.2	8.3	8.5	7.6	6.9	4.8	3.6	2.9
24.0	6.8	6.9	6.9	7.4	7.3	6.6	4.6	3.4	2.9
26.0	5.6	5.7	5.8	6.3	6.6	6.4	4.3	3.3	2.8
28.0	4.6	4.7		5.3	5.7	6.0	4.1	3.1	2.7
30.0	3.7	3.8		4.5	4.8	5.1	3.9	3.0	2.6
32.0	2.9	3.0		3.7	4.0	4.3	3.7	2.9	2.6
34.0	2.3			3.0	3.3	3.5	3.6	2.9	2.5
36.0				2.4	2.6		3.3	2.8	2.5
38.0				1.9	2.1		2.8	2.7	2.5
40.0				1.4	1.5		2.3	2.7	2.5
44.0							1.5	1.7	
48.0							0.8		
θ (°)	19~77.5	28~82.7	45~82.7	19~80.5	21~82.7	41~82.7	18~82.7	34~82.7	46~82.7
標準フック	50t			22t			7.3t		
フック質量	600kg			375kg			300kg		
標準巻掛本数	3			2			1		

注) カウンタウエイト25t、アウトリガ張出幅6.2m

■H性能

43.0mブーム+バイフォールドパワーチルトジブ

ジブ長さ (m)	3.8m			10.2m			18m		
	オフセット			オフセット			オフセット		
	5°	20°	40°	5°	20°	40°	5°	20°	40°
3.0									
3.5									
4.0									
4.5									
5.0									
6.0									
7.0									
8.0									
9.0									
10.0									
11.0									
12.0									
14.0									
16.0									
18.0									
20.0									
22.0									
24.0									
26.0									
28.0									
30.0									
32.0									
34.0									
36.0									
38.0									
40.0									
44.0									
48.0									
θ (°)	36~77.5	37~82.7	41~82.7	41~82.7	41~82.7	41~82.7	41~82.7	41~82.7	41~82.7
標準フック	50t			22t			7.3t		
フック質量	600kg			375kg			300kg		
標準巻掛本数	3			2			1		

注) カウンタウエイト25t、アウトリガ張出幅6.2m

■H性能

56.0mブーム+バイフォールドパワーチルトジブ

単位:t

ジブ長さ (m)	3.8m			10.2m			18m		
	オフセット			オフセット			オフセット		
	5°	20°	40°	5°	20°	40°	5°	20°	40°
3.0									
3.5									
4.0									
4.5									
5.0									
6.0									
7.0									
8.0									
9.0									
10.0									
11.0									
12.0		8.8							
14.0		8.3	8.0				3.9		
16.0		7.8	7.6	6.4	6.1		3.9		
18.0	7.6	7.4	7.2	6.3	5.8	5.4	3.9		
20.0	7.1	7.0	6.9	5.9	5.5	5.1	3.9	3.5	
22.0	6.7	6.6	6.5	5.6	5.2	4.9	3.9	3.4	
24.0	6.4	6.3	6.2	5.4	5.0	4.7	3.9	3.3	2.7
26.0	5.7	5.9	5.9	5.1	4.8	4.5	3.9	3.2	2.6
28.0	4.7	4.8	4.9	4.8	4.6	4.3	3.8	3.0	2.5
30.0	3.8	3.9	4.0	4.2	4.4	4.2	3.6	3.0	2.5
32.0	3.0	3.1	3.2	3.4	3.8	4.0	3.5	2.9	2.4
34.0	2.3	2.4	2.5	2.7	3.1	3.5	3.3	2.8	2.4
36.0	1.7	1.8	1.9	2.1	2.5	2.9	2.6	2.7	2.3
38.0	1.2	1.3	1.3	1.6	1.9	2.3	2.1	2.6	2.3
40.0		0.8	0.8	1.1	1.4	1.7	1.6	2.2	2.3
44.0						0.8		1.3	1.8
48.0									
θ (°)	48~77.5	46~82.7	47~82.7	51~80.5	53~82.7	50~82.7	56~82.7	56~82.7	59~82.7
標準フック	22t			7.3t					
フック質量	375kg			300kg					
標準巻掛本数	2			1					

注) カウンタウエイト25t、アウトリガ張出幅6.2m

■H性能

60.0mブーム+バイフォールドパワーチルトジブ

ジブ長さ (m)	3.8m			10.2m			18m		
	オフセット			オフセット			オフセット		
	5°	20°	40°	5°	20°	40°	5°	20°	40°
3.0									
3.5									
4.0									
4.5									
5.0									
6.0									
7.0									
8.0									
9.0									
10.0									
11.0									
12.0									
14.0		7.5	7.3						
16.0		7.1	6.9						
18.0	6.9	6.8	6.6						
20.0	6.5	6.4	6.3						
22.0	6.1	6.0	5.9						
24.0	5.8	5.7	5.6						
26.0	5.5	5.4	5.4						
28.0	4.6	4.8	4.9						
30.0	3.7	3.9	4.0						
32.0	3.0	3.1	3.2						
34.0	2.3	2.4	2.5						
36.0	1.7	1.8	1.9						
38.0	1.2	1.3	1.3						
40.0									
44.0									
48.0									
θ (°)	52~77.5	52~82.7	53~82.7	56~82.7	56~82.7	59~82.7	56~82.7	56~82.7	56~82.7
標準フック	22t			7.3t					
フック質量	375kg			300kg					
標準巻掛本数	2			1					

注) カウンタウエイト25t、アウトリガ張出幅6.2m

■I性能

12.8mブーム+パイフールドパワーチルトジブ

単位:t

ジブ長さ 作業半径 (m)	3.8m			10.2m			18m		
	オフセット			オフセット			オフセット		
	5°	20°	40°	5°	20°	40°	5°	20°	40°
3.0	40.0	32.7							
3.5	40.0	31.3	25.2				7.8		
4.0	40.0	30.0	24.5	14.6			7.8		
4.5	38.9	28.9	23.8	14.6			7.8		
5.0	36.8	27.8	23.2	14.6	14.1		7.8		
6.0	33.3	26.0	22.2	14.6	13.0		7.8		
7.0	30.4	24.4	21.3	14.6	12.1		7.5		
8.0	28.0	23.1	20.5	14.6	11.3	9.1	7.1		
9.0	26.0	22.0	19.9	13.8	10.6	8.7	6.7	5.2	
10.0	24.3	21.0	19.5	12.6	10.0	8.4	6.3	5.0	
11.0	21.0	20.2	19.2	11.4	9.4	8.0	6.0	4.7	
12.0	17.9	18.1		10.4	9.0	7.8	5.7	4.5	
14.0	13.4			8.9	8.2	7.3	5.1	4.1	3.5
16.0				7.8	7.6	7.0	4.6	3.8	3.3
18.0				6.9	7.1		4.2	3.5	3.1
20.0				6.1			3.9	3.3	3.0
22.0							3.5	3.1	2.9
24.0							3.3	3.0	2.8
26.0							3.1	2.9	
28.0							2.9		
30.0									
32.0									
34.0									
36.0									
38.0									
40.0									
θ(°)	12~77.5	35~82.7	43~82.7	15~80.5	35~82.7	49~82.7	12~82.7	33~82.7	48~82.7
標準フック	50t			22t					
フック質量	600kg			375kg					
標準巻掛本数	6			2					

注) カウンタウエイト15t、アウトリガ張出幅6.2m

■I性能

25.8mブーム+パイフールドパワーチルトジブ

ジブ長さ 作業半径 (m)	3.8m		
	オフセット		
	5°	20°	40°
3.0			
3.5			
4.0			
4.5		34.4	
5.0		33.5	
6.0		31.9	25.0
7.0	35.0	30.4	24.2
8.0	35.0	29.1	23.5
9.0	29.3	27.9	22.9
10.0	24.1	24.6	22.3
11.0	20.2	20.6	21.1
12.0	17.1	17.5	17.9
14.0	12.7	13.0	13.3
16.0	9.7	9.9	10.1
18.0	7.5	7.6	7.8
20.0	5.7	5.9	6.0
22.0	4.2	4.3	4.4
24.0	3.0	3.1	
26.0	2.0		
28.0			
30.0			
32.0			
34.0			
36.0			
38.0			
40.0			
θ(°)	18~77.5	29~82.7	40~82.7
標準フック	50t		
フック質量	600kg		
標準巻掛本数	5		

注) カウンタウエイト15t、アウトリガ張出幅6.2m

■I性能

34.4mブーム+バイフォールドパワーチルトジブ

単位:t

ジブ長さ 作業半径 (m)	3.8m			10.2m			18m		
	オフセット			オフセット			オフセット		
	5°	20°	40°	5°	20°	40°	5°	20°	40°
3.0									
3.5									
4.0									
4.5									
5.0									
6.0									
7.0		17.8	16.3					5.9	
8.0		16.9	15.6	13.4				5.9	
9.0	17.4	16.2	15.0	13.4	12.1			5.9	
10.0	16.6	15.5	14.4	13.4	11.5			5.9	
11.0	15.9	14.9	13.9	12.9	11.0			5.9	
12.0	15.2	14.3	13.4	12.4	10.6	9.0	5.9		
14.0	13.9	13.3	12.6	11.3	9.8	8.5	5.9	4.3	
16.0	10.8	11.0	11.3	10.4	9.1	8.0	5.7	4.1	
18.0	8.6	8.7	8.9	8.2	8.6	7.6	5.4	3.9	3.2
20.0	6.6	7.0	7.1	7.5	8.0	7.2	5.1	3.7	3.0
22.0	5.5	5.6	5.7	6.1	6.6	6.9	4.8	3.6	2.9
24.0	4.2	4.4	4.5	5.0	5.4	5.9	4.6	3.4	2.9
26.0	3.2	3.3	3.4	4.0	4.5	4.8	4.3	3.3	2.8
28.0	2.3	2.4		3.1	3.5	3.9	4.1	3.1	2.7
30.0	1.6	1.7		2.4	2.7	3.1	3.4	3.0	2.6
32.0	1.0	1.0		1.7	2.1	2.3	2.7	2.9	2.6
34.0				1.2	1.5	1.7	2.1	2.7	2.5
36.0					0.9		1.6	2.1	2.3
38.0							1.2	1.6	2.0
40.0							0.8	1.2	1.5
θ (°)	27~77.5	28~82.7	45~82.7	36~80.5	34~82.7	41~82.7	38~82.7	42~82.7	46~82.7
標準フック	50t			22t			7.3t		
フック質量	600kg			375kg			300kg		
標準巻掛本数	3			2			1		

注) カウンタウエイト15t、アウトリガ張出幅6.2m

■I性能

43.0mブーム+バイフォールドパワーチルトジブ

単位:t

ジブ長さ 作業半径 (m)	3.8m			10.2m			18m		
	オフセット			オフセット			オフセット		
	5°	20°	40°	5°	20°	40°	5°	20°	40°
3.0									
3.5									
4.0									
4.5									
5.0									
6.0									
7.0									
8.0									
9.0									
10.0		14.6	13.6						
11.0		14.0	13.1						5.5
12.0		13.4	12.6	10.6					5.5
14.0	13.7	12.9	12.2	10.6	9.8				5.5
16.0	12.7	12.1	11.4	10.4	9.2	8.0			5.5
18.0	10.1	10.4	10.7	9.8	8.6	7.6	5.5	4.1	
20.0	7.9	8.1	8.4	8.4	8.1	7.2	5.4	3.9	
22.0	6.2	6.4	6.6	6.7	7.4	6.9	5.2	3.7	3.0
24.0	4.7	4.9	5.1	5.3	6.0	6.6	4.9	3.6	2.9
26.0	3.5	3.6	3.8	4.1	4.8	5.4	4.7	3.4	2.8
28.0	2.5	2.6	2.7	3.1	3.7	4.3	4.1	3.3	2.7
30.0	1.6	1.7	1.8	2.2	2.8	3.3	3.2	3.2	2.7
32.0		1.0	1.1	1.5	2.0	2.4	2.5	3.1	2.6
34.0					1.3	1.7	1.8	2.6	2.6
36.0						1.1	1.3	2.0	2.5
38.0							1.4	2.0	2.0
40.0								1.5	1.5
θ (°)	51~77.5	48~82.7	49~82.7	53~80.5	53~82.7	52~82.7	55~82.7	56~82.7	58~82.7
標準フック	50t			22t			7.3t		
フック質量	600kg			375kg			300kg		
標準巻掛本数	3			2			1		

注) カウンタウエイト15t、アウトリガ張出幅6.2m

■性能

56.0mブーム+バイフォールドパワーチルトジブ

単位:t

ジブ長さ 作業半径 (m)	3.8m			10.2m			18m		
	オフセット			オフセット			オフセット		
	5°	20°	40°	5°	20°	40°	5°	20°	40°
3.0									
3.5									
4.0									
4.5									
5.0									
6.0									
7.0									
8.0									
9.0									
10.0									
11.0									
12.0		8.8							
14.0		8.3	8.0				3.9		
16.0		7.8	7.6	6.4	6.1		3.9		
18.0	7.6	7.4	7.2	6.3	5.8	5.4	3.9		
20.0	6.9	7.0	6.9	5.9	5.5	5.1	3.9	3.5	
22.0	5.6	5.7	5.9	5.6	5.2	4.9	3.9	3.4	
24.0	4.3	4.5	4.7	4.8	5.0	4.7	3.9	3.3	2.7
26.0	3.3	3.5	3.6	3.7	4.3	4.5	3.9	3.2	2.6
28.0	2.4	2.6	2.7	2.9	3.4	4.0	3.4	3.0	2.5
30.0	1.7	1.8	1.9	2.1	2.6	3.1	2.7	3.0	2.5
32.0					1.9	2.4	2.0	2.8	2.4
34.0						1.7		2.2	2.4
36.0									2.3
38.0									1.8
40.0									
θ(°)	58~77.5	59~82.7	59~82.7	62~80.5	61~82.7	61~82.7	64~82.7	65~82.7	65~82.7
標準フック	22t			7.3t					
フック質量	375kg			300kg					
標準巻掛本数	2			1					

注) カウンタウエイト15t、アウトリガ張出幅6.2m

■性能

60.0mブーム+バイフォールドパワーチルトジブ

ジブ長さ 作業半径 (m)	3.8m			10.2m			18m		
	オフセット			オフセット			オフセット		
	5°	20°	40°	5°	20°	40°	5°	20°	40°
3.0									
3.5									
4.0									
4.5									
5.0									
6.0									
7.0									
8.0									
9.0									
10.0									
11.0									
12.0									
14.0									
16.0									
18.0									
20.0									
22.0									
24.0									
26.0									
28.0									
30.0									
32.0									
34.0									
36.0									
38.0									
40.0									
θ(°)	62~77.5	63~82.7	61~82.7	63~80.5	62~82.7	62~82.7	65~82.7	66~82.7	66~82.7
標準フック	22t			7.3t					
フック質量	375kg			300kg					
標準巻掛本数	2			1					

注) カウンタウエイト15t、アウトリガ張出幅6.2m

■J性能

12.8mブーム+バイフォールドパワーチルトジブ

単位:t

ジブ長さ 作業半径 (m)	3.8m			10.2m			18m		
	オフセット			オフセット			オフセット		
	5°	20°	40°	5°	20°	40°	5°	20°	40°
3.0	40.0	32.7						7.8	
3.5	40.0	31.3	25.2					7.8	
4.0	40.0	30.0	24.5	14.6				7.8	
4.5	38.9	28.9	23.8	14.6				7.8	
5.0	36.8	27.8	23.2	14.6	14.1			7.8	
6.0	33.3	26.0	22.2	14.6	13.0			7.8	
7.0	30.4	24.4	21.3	14.6	12.1			7.5	
8.0	28.0	23.1	20.5	14.6	11.3	9.1	7.1		
9.0	22.7	22.0	19.9	13.8	10.6	8.7	6.7	5.2	
10.0	18.5	18.8	19.1	12.6	10.0	8.4	6.3	5.0	
11.0	15.4	15.6	15.8	11.4	9.4	8.0	6.0	4.7	
12.0	12.9	13.1		10.4	9.0	7.8	5.7	4.5	
14.0	9.3			8.9	8.2	7.3	5.1	4.1	3.5
16.0				7.8	7.6	7.0	4.6	3.8	3.3
18.0				6.9	7.1		4.2	3.5	3.1
20.0				5.6			3.9	3.3	3.0
22.0							3.5	3.1	2.9
24.0							3.3	3.0	2.8
26.0							3.1	2.9	
28.0							2.9		
30.0									
32.0									
34.0									
36.0									
θ (°)	12~77.5	35~82.7	43~82.7	15~80.5	35~82.7	49~82.7	12~82.7	33~82.7	48~82.7
標準フック	50t			22t					
フック質量	600kg			375kg					
標準巻掛本数	6			2					

注) カウンタウエイト6t、アウトリガ張出幅6.2m

■J性能

25.8mブーム+バイフォールドパワーチルトジブ

単位:t

ジブ長さ 作業半径 (m)	3.8m			10.2m			18m		
	オフセット			オフセット			オフセット		
	5°	20°	40°	5°	20°	40°	5°	20°	40°
3.0									
3.5									
4.0									
4.5									
5.0									7.4
6.0									7.4
7.0									7.4
8.0		35.0	30.4	24.2	14.6	14.6			7.4
9.0		27.7	28.5	23.5	14.6	13.9			7.4
10.0		21.8	22.5	22.9	14.6	13.2			7.4
11.0		17.7	18.2	18.7	14.6	12.6	9.3	7.1	
12.0		14.6	15.0	15.5	14.6	12.0	9.0	6.9	
14.0		12.2	12.5	12.9	13.5	11.5	8.8	6.6	4.8
16.0		8.7	9.0	9.2	9.9	10.6	8.3	6.1	4.4
18.0		6.2	6.5	6.7	7.5	8.3	7.9	5.7	4.2
20.0		4.1	4.3	4.5	5.5	6.4	7.1	5.3	3.9
22.0		2.5	2.7	2.8	3.9	4.6	5.3	4.9	3.7
24.0		1.4	1.5	1.6	2.7	3.3	3.9	4.0	3.5
26.0					1.8	2.3	2.7	3.0	3.3
28.0					1.0	1.4	1.7	2.2	2.9
30.0								1.5	2.2
32.0								1.0	1.5
34.0									1.0
36.0									0.8
θ (°)	36~77.5	37~82.7	40~82.7	39~80.5	42~82.7	45~82.7	44~82.7	45~82.7	45~82.7
標準フック	50t			22t					
フック質量	600kg			375kg					
標準巻掛本数	5			2					

注) カウンタウエイト6t、アウトリガ張出幅6.2m



■J性能

34.4mブーム+バイフールドパワーチルトジブ

単位:t

ジブ長さ 作業半径 (m)	3.8m			10.2m			18m		
	オフセット			オフセット			オフセット		
	5°	20°	40°	5°	20°	40°	5°	20°	40°
3.0									
3.5									
4.0									
4.5									
5.0									
6.0									
7.0		17.8	16.3					5.9	
8.0		16.9	15.6	13.4				5.9	
9.0	17.4	16.2	15.0	13.4	12.1			5.9	
10.0	16.6	15.5	14.4	13.4	11.5			5.9	
11.0	15.9	14.9	13.9	12.9	11.0			5.9	
12.0	13.4	13.8	13.4	12.4	10.6	9.0		5.9	
14.0	9.8	10.1	10.4	10.5	9.8	8.5	5.9	4.3	
16.0	7.4	7.6	7.8	8.0	8.8	8.0	5.7	4.1	
18.0	5.4	5.6	5.8	6.2	6.9	7.6	5.4	3.9	3.2
20.0	3.8	4.0	4.1	4.5	5.2	6.0	5.1	3.7	3.0
22.0	2.6	2.7	2.9	3.3	3.9	4.5	4.4	3.6	2.9
24.0	1.6	1.8	1.9	2.4	2.9	3.4	3.4	3.4	2.9
26.0	0.9	1.0	1.1	1.6	2.0	2.5	2.6	3.3	2.8
28.0				1.0	1.3	1.7	1.9	2.6	2.7
30.0						1.0	1.3	1.9	2.8
32.0							0.8	1.4	2.0
34.0								0.9	1.4
36.0									0.9
θ (°)	44~77.5	44~82.7	45~82.7	48~80.5	51~82.7	50~82.7	51~82.7	52~82.7	53~82.7
標準フック	50t			22t			7.3t		
フック質量	600kg			375kg			300kg		
標準巻掛本数	3			2			1		

注) カウンタウエイト6t、アウトリガ張出幅6.2m

■J性能

43.0mブーム+バイフールドパワーチルトジブ

単位:t

ジブ長さ 作業半径 (m)	3.8m			10.2m			18m		
	オフセット			オフセット			オフセット		
	5°	20°	40°	5°	20°	40°	5°	20°	40°
3.0									
3.5									
4.0									
4.5									
5.0									
6.0									
7.0									
8.0									
9.0									
10.0				14.6	13.6				
11.0				14.0	13.1				5.5
12.0				13.4	12.6	10.6			5.5
14.0	12.7	12.9	12.2	10.6	9.8				5.5
16.0	9.1	9.5	9.8	9.7	9.2	8.0			5.5
18.0	6.7	7.0	7.3	7.2	8.2	7.6	5.5	4.1	
20.0	4.6	4.9	5.2	5.2	6.2	7.1	5.4	3.9	
22.0	3.1	3.3	3.5	3.7	4.5	5.4	4.8	3.7	3.0
24.0	1.9	2.1	2.3	2.5	3.2	3.9	3.5	3.6	2.9
26.0					2.2	2.8	2.6	3.4	2.8
28.0						1.9		2.7	2.7
30.0							1.9	2.7	2.7
32.0									2.1
34.0									
36.0									
θ (°)	60~77.5	61~82.7	61~82.7	63~80.5	63~82.7	63~82.7	66~82.7	66~82.7	68~82.7
標準フック	50t			22t			7.3t		
フック質量	600kg			375kg			300kg		
標準巻掛本数	3			2			1		

注) カウンタウエイト6t、アウトリガ張出幅6.2m

■J性能

56.0mブーム+バイフォールドパワーチルトジブ

単位:t

ジブ長さ 作業半径 (m)	3.8m			10.2m			18m		
	オフセット			オフセット			オフセット		
	5°	20°	40°	5°	20°	40°	5°	20°	40°
3.0									
3.5									
4.0									
4.5									
5.0									
6.0									
7.0									
8.0									
9.0									
10.0									
11.0									
12.0		8.8							
14.0		8.3	8.0				3.9		
16.0		7.8	7.6	6.4	6.1		3.9		
18.0	5.5	5.8	6.1	6.0	5.8	5.4	3.9		
20.0	3.9	4.2	4.4	4.4	5.1	5.1	3.9	3.5	
22.0	2.7	2.9	3.1	3.1	3.8	4.6	3.7	3.4	
24.0					2.8	3.4		3.3	2.7
26.0						2.5		2.8	2.6
28.0									2.5
30.0									2.3
32.0									
34.0									
36.0									
θ (°)	67~77.5	68~82.7	68~82.7	69~80.5	69~82.7	70~82.7	72~82.7	72~82.7	72~82.7
標準フック	22t			7.3t					
フック質量	375kg			300kg					
標準巻掛本数	2			1					

注) カウンタウエイト6t、アウトリガ張出幅6.2m

■K性能

12.8mブーム+バイフォールドパワーチルトジブ

単位:t

ジブ長さ 作業半径 (m)	3.8m			10.2m			18m		
	オフセット			オフセット			オフセット		
	5°	20°	40°	5°	20°	40°	5°	20°	40°
3.0	40.0	32.7							
3.5	40.0	31.3	25.2				7.8		
4.0	40.0	30.0	24.5	14.6			7.8		
4.5	38.9	28.9	23.8	14.6			7.8		
5.0	36.8	27.8	23.2	14.6	14.1		7.8		
6.0	33.3	26.0	22.2	14.6	13.0		7.8		
7.0	29.9	24.4	21.3	14.6	12.1		7.5		
8.0	22.5	23.0	20.5	14.6	11.3	9.1	7.1		
9.0	17.6	18.0	18.4	13.8	10.6	8.7	6.7	5.2	
10.0	14.1	14.4	14.7	12.6	10.0	8.4	6.3	5.0	
11.0	11.5	11.7	11.9	11.4	9.4	8.0	6.0	4.7	
12.0	8.7	9.0		10.4	9.0	7.8	5.7	4.5	
14.0	5.1			7.9	8.2	7.3	5.1	4.1	3.5
16.0				5.5	6.1	6.7	4.6	3.8	3.3
18.0				3.8	4.2		4.2	3.5	3.1
20.0				2.7			3.9	3.3	3.0
22.0							3.2	3.1	2.9
24.0							2.4	2.9	2.8
26.0							1.8	2.1	
28.0							1.3		
30.0									
θ (°)	12~77.5	35~82.7	43~82.7	15~80.5	35~82.7	49~82.7	12~82.7	33~82.7	48~82.7
標準フック	50t			22t					
フック質量	600kg			375kg					
標準巻掛本数	6			2					

注) カウンタウエイト0t、アウトリガ張出幅7.5mまたは、カウンタウエイト0t、アウトリガ張出幅6.2m

■K性能

25.8mブーム+バイフォールドパワーチルトジブ

単位:t

ジブ長さ 作業半径 (m)	3.8m			10.2m			18m		
	オフセット			オフセット			オフセット		
	5°	20°	40°	5°	20°	40°	5°	20°	40°
3.0									
3.5									
4.0									
4.5				34.4					
5.0				33.5					7.4
6.0				31.9	25.0				7.4
7.0	28.8	29.8	24.2	14.6	14.6				7.4
8.0	21.5	22.3	23.1	14.6	13.9				7.4
9.0	16.7	17.3	18.0	14.6	13.2				7.4
10.0	13.3	13.8	14.3	14.6	12.6	9.3	7.1		
11.0	10.4	11.0	11.6	12.0	12.0	9.0	6.9		
12.0	7.7	8.2	8.8	9.5	11.3	8.8	6.6	4.8	
14.0	4.2	4.6	5.0	5.9	7.2	8.3	6.1	4.4	
16.0	2.1	2.4	2.6	3.6	4.7	5.8	5.2	4.2	3.4
18.0		0.8	1.0	2.1	2.9	3.8	3.5	3.9	3.2
20.0				1.0	1.6	2.4	2.3	3.5	3.1
22.0						1.3	1.4	2.4	3.0
24.0								1.5	2.5
26.0								0.8	1.7
28.0									1.0
30.0									
θ (°)	53~77.5	49~82.7	50~82.7	53~80.5	56~82.7	55~82.7	58~82.7	57~82.7	59~82.7
標準フック	50t			22t					
フック質量	600kg			375kg					
標準巻掛本数	5			2					

注) カウンタウエイト0t、アウトリガ張出幅7.5mまたは、カウンタウエイト0t、アウトリガ張出幅6.2m

■K性能

34.4mブーム+バイフォールドパワーチルトジブ

単位:t

ジブ長さ 作業半径 (m)	3.8m			10.2m			18m		
	オフセット			オフセット			オフセット		
	5°	20°	40°	5°	20°	40°	5°	20°	40°
3.0									
3.5									
4.0									
4.5									
5.0									
6.0									
7.0		17.8	16.3					5.9	
8.0		16.9	15.6	13.4				5.9	
9.0	17.4	16.2	15.0	13.4	12.1			5.9	
10.0	14.6	15.1	14.4	13.4	11.5			5.9	
11.0	12.0	12.4	12.9	12.7	11.0			5.9	
12.0	9.5	10.0	10.5	10.4	10.6	9.0		5.9	
14.0	5.8	6.2	6.5	6.6	7.9	8.5	5.9		4.3
16.0	3.5	3.8	4.1	4.3	5.3	6.5	5.7		4.1
18.0	1.9	2.2	2.4	2.7	3.5	4.5	4.0	3.9	3.2
20.0	0.8	1.0	1.2	1.6	2.3	3.0	2.7	3.7	3.0
22.0					1.3	1.9	1.8	2.8	2.9
24.0						1.1	1.0	1.9	2.9
26.0								1.2	2.1
28.0									1.4
30.0									0.8
θ (°)	56~77.5	57~82.7	57~82.7	61~80.5	61~82.7	60~82.7	62~82.7	63~82.7	63~82.7
標準フック	50t			22t			7.3t		
フック質量	600kg			375kg			300kg		
標準巻掛本数	3			2			1		

注) カウンタウエイト0t、アウトリガ張出幅7.5mまたは、カウンタウエイト0t、アウトリガ張出幅6.2m

■K性能

43.0mブーム+バイフォールドパワーチルトジブ

単位:t

ジブ長さ 作業半径 (m)	3.8m			10.2m			18m		
	オフセット			オフセット			オフセット		
	5°	20°	40°	5°	20°	40°	5°	20°	40°
3.0									
3.5									
4.0									
4.5									
5.0									
6.0									
7.0									
8.0									
9.0		14.6	13.6						
10.0		14.0	13.1					5.5	
11.0				11.7	12.2	10.6			5.5
12.0		8.5	9.1	9.7	9.2	9.8			5.5
14.0		4.9	5.3	5.8	5.6	7.0	8.0		5.5
16.0		2.7	3.0	3.4	3.3	4.5	5.8	4.7	4.1
18.0						2.8	3.8	3.0	3.9
20.0							2.4		3.0
22.0								2.1	2.9
24.0									2.5
26.0									1.6
28.0									
30.0									
θ (°)	65~77.5	66~82.7	67~82.7	68~80.5	68~82.7	69~82.7	70~82.7	70~82.7	72~82.7
標準フック	50t			22t			7.3t		
フック質量	600kg			375kg			300kg		
標準巻掛本数	3			2			1		

注) カウンタウエイト0t、アウトリガ張出幅7.5mまたは、カウンタウエイト0t、アウトリガ張出幅6.2m

■L性能

12.8mブーム+バイフォールドパワーチルトジブ

単位:t

ジブ長さ 作業半径 (m)	3.8m			10.2m			18m		
	オフセット			オフセット			オフセット		
	5°	20°	40°	5°	20°	40°	5°	20°	40°
3.0	40.0	32.7							
3.5	40.0	31.3	25.2				7.8		
4.0	40.0	30.0	24.5	14.6			7.8		
4.5	38.9	28.9	23.8	14.6			7.8		
5.0	36.8	27.8	23.2	14.6	14.1		7.8		
6.0	33.3	26.0	22.2	14.6	13.0		7.8		
7.0	30.4	24.4	21.3	14.6	12.1		7.5		
8.0	28.0	23.1	20.5	14.6	11.3	9.1	7.1		
9.0	26.0	22.0	19.9	13.8	10.6	8.7	6.7	5.2	
10.0	24.3	21.0	19.5	12.6	10.0	8.4	6.3	5.0	
11.0	22.8	20.2	19.2	11.4	9.4	8.0	6.0	4.7	
12.0	19.7	19.6		10.4	9.0	7.8	5.7	4.5	
14.0	15.1			8.9	8.2	7.3	5.1	4.1	3.5
16.0				7.8	7.6	7.0	4.6	3.8	3.3
18.0				6.9	7.1		4.2	3.5	3.1
20.0				6.1			3.9	3.3	3.0
22.0							3.5	3.1	2.9
24.0							3.3	3.0	2.8
26.0							3.1	2.9	
28.0							2.9		
30.0									
32.0									
34.0									
36.0									
38.0									
40.0									
44.0									
θ (°)	12~77.5	35~82.7	43~82.7	15~80.5	35~82.7	49~82.7	12~82.7	33~82.7	48~82.7
標準フック	50t			22t					
フック質量	600kg			375kg					
標準巻掛本数	6			2					

注) カウンタウエイト28t、アウトリガ張出幅5.0m

■L性能

25.8mブーム+バイフォールドパワーチルトジブ

単位:t

ジブ長さ 作業半径 (m)	3.8m			10.2m			18m		
	オフセット			オフセット			オフセット		
	5°	20°	40°	5°	20°	40°	5°	20°	40°
3.0									
3.5									
4.0									
4.5				34.4					
5.0				33.5					7.4
6.0				31.9	25.0				7.4
7.0	35.0	30.4	24.2	14.6	14.6				7.4
8.0	35.0	29.1	23.5	14.6	13.9				7.4
9.0	30.9	27.9	22.9	14.6	13.2				7.4
10.0	25.9	26.4	22.3	14.6	12.6	9.3	7.1		
11.0	22.0	22.4	21.8	14.6	12.0	9.0	6.9		
12.0	19.0	19.3	19.7	14.6	11.5	8.8	6.6	4.8	
14.0	14.5	14.8	15.0	14.6	10.6	8.3	6.1	4.4	
16.0	11.3	11.5	11.7	12.5	9.8	7.9	5.7	4.2	3.4
18.0	9.0	9.1	9.3	10.1	9.2	7.6	5.3	3.9	3.2
20.0	7.2	7.3	7.4	8.3	8.6	7.3	4.9	3.7	3.1
22.0	5.6	5.7	5.8	6.9	7.3	7.1	4.6	3.5	3.0
24.0	4.3	4.4		5.7	6.1	6.4	4.3	3.3	2.9
26.0	3.2			4.6	5.0	5.3	4.0	3.2	2.8
28.0				3.6	4.0		3.8	3.1	2.7
30.0				2.9	3.1		3.6	3.0	2.7
32.0				2.2	2.3		3.3	2.9	2.6
34.0							2.7	2.8	2.6
36.0							2.2	2.5	
38.0							1.7	1.9	
40.0							1.3		
44.0									
θ (°)	18~77.5	29~82.7	40~82.7	18~80.5	21~82.7	45~82.7	16~82.7	29~82.7	45~82.7
標準フック	50t			22t					
フック質量	600kg			375kg					
標準巻掛本数	5			2					

注) カウンタウエイト28t、アウトリガ張出幅5.0m

■L性能

34.4mブーム+バイフォールドパワーチルトジブ

単位:t

ジブ長さ 作業半径 (m)	3.8m			10.2m			18m		
	オフセット			オフセット			オフセット		
	5°	20°	40°	5°	20°	40°	5°	20°	40°
3.0									
3.5									
4.0									
4.5									
5.0									
6.0									
7.0		17.8	16.3				5.9		
8.0		16.9	15.6	13.4			5.9		
9.0	17.4	16.2	15.0	13.4	12.1		5.9		
10.0	16.6	15.5	14.4	13.4	11.5		5.9		
11.0	15.9	14.9	13.9	12.9	11.0		5.9		
12.0	15.2	14.3	13.4	12.4	10.6	9.0	5.9		
14.0	14.1	13.3	12.6	11.3	9.8	8.5	5.9	4.3	
16.0	12.4	12.5	11.9	10.4	9.1	8.0	5.7	4.1	
18.0	10.0	10.2	10.4	9.7	8.6	7.6	5.4	3.9	3.2
20.0	8.2	8.3	8.5	8.8	8.1	7.2	5.1	3.7	3.0
22.0	6.7	6.9	7.0	7.3	7.6	6.9	4.8	3.6	2.9
24.0	5.5	5.6	5.7	6.1	6.6	6.6	4.6	3.4	2.9
26.0	4.4	4.5	4.6	5.2	5.5	5.9	4.3	3.3	2.8
28.0	3.5	3.6		4.2	4.6	5.0	4.1	3.1	2.7
30.0	2.7	2.7		3.4	3.8	4.1	3.9	3.0	2.6
32.0	2.0	2.0		2.7	3.0	3.3	3.7	2.9	2.6
34.0	1.4			2.1	2.4	2.6	3.1	2.9	2.5
36.0				1.6	1.8		2.5	2.8	2.5
38.0				1.1	1.3		2.0	2.4	2.5
40.0					0.8		1.6	1.9	2.3
44.0							0.8	1.1	
θ (°)	19~77.5	28~82.7	45~82.7	26~80.5	21~82.7	41~82.7	30~82.7	34~82.7	46~82.7
標準フック	50t			22t			7.3t		
フック質量	600kg			375kg			300kg		
標準巻掛本数	3			2			1		

注) カウンタウエイト28t、アウトリガ張出幅5.0m

■L性能

43.0mブーム+バイフォールドパワーチルトジブ

単位:t

ジブ長さ 作業半径 (m)	3.8m			10.2m			18m		
	オフセット			オフセット			オフセット		
	5°	20°	40°	5°	20°	40°	5°	20°	40°
3.0									
3.5									
4.0									
4.5									
5.0									
6.0									
7.0									
8.0									
9.0		14.6	13.6						
10.0		14.0	13.1					5.5	
11.0		13.4	12.6	10.6				5.5	
12.0	13.7	12.9	12.2	10.6	9.8			5.5	
14.0	12.7	12.1	11.4	10.4	9.2	8.0		5.5	
16.0	11.8	11.3	10.8	9.8	8.6	7.6		5.5	4.1
18.0	9.4	9.6	9.8	9.2	8.1	7.2		5.4	3.9
20.0	7.6	7.8	7.9	8.1	7.7	6.9		5.2	3.7
22.0	6.1	6.3	6.4	6.6	7.2	6.6		4.9	3.6
24.0	4.8	4.9	5.1	5.4	6.0	6.3		4.7	3.4
26.0	3.7	3.8	3.9	4.3	4.9	5.4		4.5	3.3
28.0	2.7	2.9	3.0	3.4	3.9	4.4		4.3	3.2
30.0	1.9	2.0	2.1	2.6	3.0	3.5		3.5	3.1
32.0	1.3	1.3	1.4	1.9	2.3	2.7		2.8	3.0
34.0				0.8	1.3	1.6		2.0	2.2
36.0					0.8	1.1		1.4	1.6
38.0								0.8	1.2
40.0									1.7
44.0									0.8
θ (°)	44~77.5	45~82.7	41~82.7	45~80.5	47~82.7	46~82.7	50~82.7	51~82.7	49~82.7
標準フック	50t			22t			7.3t		
フック質量	600kg			375kg			300kg		
標準巻掛本数	3			2			1		

注) カウンタウエイト28t、アウトリガ張出幅5.0m

■L性能

56.0mブーム+バイフォールドパワーチルトジブ

単位:t

ジブ長さ 作業半径 (m)	3.8m			10.2m			18m		
	オフセット			オフセット			オフセット		
	5°	20°	40°	5°	20°	40°	5°	20°	40°
3.0									
3.5									
4.0									
4.5									
5.0									
6.0									
7.0									
8.0									
9.0									
10.0									
11.0									
12.0			8.8						
14.0			8.3					3.9	
16.0			7.8	8.0				3.9	
18.0	7.6	7.4	7.2	6.3	5.8	5.4	3.9		
20.0	7.1	7.0	6.9	5.9	5.5	5.1	3.9	3.5	
22.0	6.7	6.6	6.5	5.6	5.2	4.9	3.9	3.4	
24.0	5.6	5.8	5.9	5.4	5.0	4.7	3.9	3.3	2.7
26.0	4.5	4.6	4.8	4.9	4.8	4.5	3.9	3.2	2.6
28.0	3.5	3.7	3.8	4.0	4.5	4.3	3.8	3.0	2.5
30.0	2.7	2.9	3.0	3.2	3.6	4.1	3.6	3.0	2.5
32.0	2.0	2.2	2.3	2.5	2.9	3.4	3.0	2.9	2.4
34.0	1.4	1.5	1.6	1.9	2.3	2.7	2.4	2.8	2.4
36.0		1.0	1.1	1.3	1.7	2.0	1.8	2.5	2.3
38.0					1.2	1.5	1.3	1.9	2.3
40.0								1.5	2.1
44.0									
θ (°)	54~77.5	52~82.7	52~82.7	55~80.5	55~82.7	57~82.7	58~82.7	59~82.7	63~82.7
標準フック	22t			7.3t			7.3t		
フック質量	375kg			300kg			300kg		
標準巻掛本数	2			1			1		

注) カウンタウエイト28t、アウトリガ張出幅5.0m

■L性能

60.0mブーム+バイフォールドパワーチルトジブ

単位:t

ジブ長さ 作業半径 (m)	3.8m			10.2m			18m		
	オフセット			オフセット			オフセット		
	5°	20°	40°	5°	20°	40°	5°	20°	40°
3.0									
3.5									
4.0									
4.5									
5.0									
6.0									
7.0									
8.0									
9.0									
10.0									
11.0									
12.0									
14.0									
16.0					7.5	7.3			3.6
18.0					7.1	6.9	5.7	5.6	3.6
20.0					6.9	6.8	6.6	5.7	5.3
22.0					6.5	6.4	6.3	5.4	5.1
24.0					6.1	6.0	5.9	5.1	4.8
26.0					5.6	5.7	5.6	4.9	4.6
28.0					4.5	4.6	4.8	4.7	4.4
30.0					3.5	3.7	3.8	3.9	4.2
32.0					2.7	2.9	3.0	3.1	3.6
34.0					2.0	2.1	2.3	2.4	2.9
36.0					1.4	1.5	1.6	1.8	2.2
38.0								1.6	2.0
40.0									1.7
44.0									
θ (°)	56~77.5	57~82.7	57~82.7	60~80.5	59~82.7	59~82.7	62~82.7	63~82.7	64~82.7
標準フック	22t			7.3t			7.3t		
フック質量	375kg			300kg			300kg		
標準巻掛本数	2			1			1		

注) カウンタウエイト28t、アウトリガ張出幅5.0m

■M性能

12.8mブーム+バイフォールドパワーチルトジブ

単位:t

ジブ長さ 作業半径 (m)	3.8m			10.2m			18m		
	オフセット			オフセット			オフセット		
	5°	20°	40°	5°	20°	40°	5°	20°	40°
3.0	40.0	32.7							
3.5	40.0	31.3	25.2				7.8		
4.0	40.0	30.0	24.5	14.6			7.8		
4.5	38.9	28.9	23.8	14.6			7.8		
5.0	36.8	27.8	23.2	14.6	14.1		7.8		
6.0	33.3	26.0	22.2	14.6	13.0		7.8		
7.0	30.4	24.4	21.3	14.6	12.1		7.5		
8.0	28.0	23.1	20.5	14.6	11.3	9.1	7.1		
9.0	26.0	22.0	19.9	13.8	10.6	8.7	6.7	5.2	
10.0	24.3	21.0	19.5	12.6	10.0	8.4	6.3	5.0	
11.0	21.1	20.2	19.2	11.4	9.4	8.0	6.0	4.7	
12.0	18.2	18.4		10.4	9.0	7.8	5.7	4.5	
14.0	13.9			8.9	8.2	7.3	5.1	4.1	3.5
16.0				7.8	7.6	7.0	4.6	3.8	3.3
18.0				6.9	7.1		4.2	3.5	3.1
20.0				6.1			3.9	3.3	3.0
22.0							3.5	3.1	2.9
24.0							3.3	3.0	2.8
26.0							3.1	2.9	
28.0							2.9		
30.0									
32.0									
34.0									
36.0									
38.0									
40.0									
$\theta (^{\circ})$	12~77.5	35~82.7	43~82.7	15~80.5	35~82.7	49~82.7	12~82.7	33~82.7	48~82.7
標準フック	50t			22t					
フック質量	600kg			375kg					
標準巻掛本数	6			2					

注) カウンタウエイト25t、アウトリガ張出幅5.0m

■M性能

25.8mブーム+バイフォールドパワーチルトジブ

単位:t

ジブ長さ 作業半径 (m)	3.8m			10.2m			18m		
	オフセット			オフセット			オフセット		
	5°	20°	40°	5°	20°	40°	5°	20°	40°
3.0									
3.5									
4.0									
4.5				34.4					
5.0				33.5					7.4
6.0				31.9	25.0				7.4
7.0	35.0	30.4	24.2	14.6	14.6				7.4
8.0	35.0	29.1	23.5	14.6	13.9				7.4
9.0	28.7	27.9	22.9	14.6	13.2				7.4
10.0	24.0	24.5	22.3	14.6	12.6	9.3	7.1		
11.0	20.3	20.8	21.2	14.6	12.0	9.0	6.9		
12.0	17.5	17.8	18.2	14.6	11.5	8.8	6.6	4.8	
14.0	13.2	13.5	13.8	14.4	10.6	8.3	6.1	4.4	
16.0	10.3	10.5	10.7	11.4	9.8	7.9	5.7	4.2	3.4
18.0	8.1	8.2	8.4	9.2	9.2	7.6	5.3	3.9	3.2
20.0	6.3	6.5	6.6	7.5	8.0	7.3	4.9	3.7	3.1
22.0	4.8	4.9	5.0	6.1	6.6	7.1	4.6	3.5	3.0
24.0	3.6	3.7		5.0	5.4	5.8	4.3	3.3	2.9
26.0	2.6			3.9	4.3	4.7	4.0	3.2	2.8
28.0				3.0	3.3		3.8	3.1	2.7
30.0				2.3	2.5		3.5	3.0	2.7
32.0				1.6	1.8		2.8	2.9	2.6
34.0							2.2	2.6	2.6
36.0							1.7	2.0	
38.0							1.2	1.5	
40.0							0.8		
$\theta (^{\circ})$	18~77.5	29~82.7	40~82.7	18~80.5	21~82.7	45~82.7	16~82.7	29~82.7	45~82.7
標準フック	50t			22t					
フック質量	600kg			375kg					
標準巻掛本数	5			2					

注) カウンタウエイト25t、アウトリガ張出幅5.0m



■M性能

34.4mブーム+バイフォールドパワーチルトジブ

単位:t

ジブ長さ 作業半径 (m)	3.8m			10.2m			18m		
	オフセット			オフセット			オフセット		
	5°	20°	40°	5°	20°	40°	5°	20°	40°
3.0									
3.5									
4.0									
4.5									
5.0									
6.0									
7.0		17.8	16.3				5.9		
8.0		16.9	15.6	13.4			5.9		
9.0	17.4	16.2	15.0	13.4	12.1		5.9		
10.0	16.6	15.5	14.4	13.4	11.5		5.9		
11.0	15.9	14.9	13.9	12.9	11.0		5.9		
12.0	15.2	14.3	13.4	12.4	10.6	9.0	5.9		
14.0	14.1	13.3	12.6	11.3	9.8	8.5	5.9	4.3	
16.0	11.3	11.6	11.8	10.4	9.1	8.0	5.7	4.1	
18.0	9.1	9.3	9.5	9.7	8.6	7.6	5.4	3.9	3.2
20.0	7.4	7.5	7.7	8.0	8.1	7.2	5.1	3.7	3.0
22.0	6.0	6.1	6.2	6.6	7.1	6.9	4.8	3.6	2.9
24.0	4.8	4.9	5.0	5.5	5.9	6.4	4.6	3.4	2.9
26.0	3.7	3.8	3.9	4.5	4.9	5.3	4.3	3.3	2.8
28.0	2.8	2.9		3.6	4.0	4.4	4.1	3.1	2.7
30.0	2.1	2.2		2.8	3.2	3.5	3.8	3.0	2.6
32.0	1.4	1.5		2.2	2.5	2.8	3.1	2.9	2.6
34.0	0.9			1.6	1.9	2.1	2.6	2.9	2.5
36.0				1.1	1.3		2.0	2.5	2.5
38.0					0.8		1.6	2.0	2.4
40.0							1.2	1.5	1.8
θ (°)	19~77.5	28~82.7	45~82.7	31~80.5	28~82.7	41~82.7	38~82.7	42~82.7	46~82.7
標準フック	50t			22t			7.3t		
フック質量	600kg			375kg			300kg		
標準巻掛本数	3			2			1		

注) カウンタウエイト25t、アウトリガ張出幅5.0m

■M性能

43.0mブーム+バイフォールドパワーチルトジブ

単位:t

ジブ長さ 作業半径 (m)	3.8m			10.2m			18m		
	オフセット			オフセット			オフセット		
	5°	20°	40°	5°	20°	40°	5°	20°	40°
3.0									
3.5									
4.0									
4.5									
5.0									
6.0									
7.0									
8.0									
9.0		14.6	13.6						
10.0		14.0	13.1					5.5	
11.0		13.4	12.6	10.6				5.5	
12.0	13.7	12.9	12.2	10.6	9.8			5.5	
14.0	12.7	12.1	11.4	10.4	9.2	8.0		5.5	
16.0	10.7	11.0	10.8	9.8	8.6	7.6		5.5	4.1
18.0	8.5	8.7	8.9	9.0	8.1	7.2		5.4	3.9
20.0	6.8	7.0	7.1	7.3	7.7	6.9		5.2	3.7
22.0	5.3	5.5	5.7	5.9	6.5	6.6		4.9	3.6
24.0	4.0	4.2	4.4	4.7	5.3	5.9		4.7	3.4
26.0	3.0	3.1	3.3	3.6	4.2	4.8		4.5	3.3
28.0	2.1	2.2	2.3	2.7	3.2	3.8		3.7	3.2
30.0	1.4	1.5	1.6	2.0	2.4	2.9		3.0	3.1
32.0		0.8	0.9	1.3	1.7	2.2		2.3	3.0
34.0				0.8	1.1	1.5		1.7	2.4
36.0						0.9		1.2	1.8
38.0								1.3	1.8
40.0									1.3
θ (°)	47~77.5	45~82.7	45~82.7	48~80.5	50~82.7	49~82.7	53~82.7	54~82.7	55~82.7
標準フック	50t			22t			7.3t		
フック質量	600kg			375kg			300kg		
標準巻掛本数	3			2			1		

注) カウンタウエイト25t、アウトリガ張出幅5.0m

■M性能

56.0mブーム+バイフォールドパワーチルトジブ

単位:t

ジブ長さ 作業半径 (m)	3.8m			10.2m			18m		
	オフセット			オフセット			オフセット		
	5°	20°	40°	5°	20°	40°	5°	20°	40°
3.0									
3.5									
4.0									
4.5									
5.0									
6.0									
7.0									
8.0									
9.0									
10.0									
11.0									
12.0		8.8							
14.0		8.3	8.0				3.9		
16.0		7.8	7.6	6.4	6.1		3.9		
18.0	7.6	7.4	7.2	6.3	5.8	5.4	3.9		
20.0	7.1	7.0	6.9	5.9	5.5	5.1	3.9	3.5	
22.0	6.1	6.3	6.4	5.6	5.2	4.9	3.9	3.4	
24.0	4.9	5.0	5.2	5.3	5.0	4.7	3.9	3.3	2.7
26.0	3.8	4.0	4.1	4.2	4.8	4.5	3.9	3.2	2.6
28.0	2.9	3.1	3.2	3.4	3.9	4.3	3.8	3.0	2.5
30.0	2.2	2.3	2.4	2.6	3.1	3.6	3.1	3.0	2.5
32.0	1.5	1.6	1.7	1.9	2.4	2.8	2.5	2.9	2.4
34.0					1.8	2.2	1.9	2.6	2.4
36.0						1.6		2.0	2.3
38.0								1.5	2.2
40.0									1.6
θ (°)	56~77.5	56~82.7	57~82.7	60~80.5	59~82.7	59~82.7	62~82.7	61~82.7	63~82.7
標準フック	22t			7.3t					
フック質量	375kg			300kg					
標準巻掛本数	2			1					

注) カウンタウエイト25t、アウトリガ張出幅5.0m

■M性能

60.0mブーム+バイフォールドパワーチルトジブ

単位:t

ジブ長さ 作業半径 (m)	3.8m			10.2m			18m		
	オフセット			オフセット			オフセット		
	5°	20°	40°	5°	20°	40°	5°	20°	40°
3.0									
3.5									
4.0									
4.5									
5.0									
6.0									
7.0									
8.0									
9.0									
10.0									
11.0									
12.0									
14.0									
16.0				7.5	7.3				3.6
18.0	6.9	6.8	6.6	5.7	5.6				3.6
20.0	6.5	6.4	6.3	5.4	5.1	4.7			3.6
22.0	6.1	6.0	5.9	5.1	4.8	4.5	3.6	3.3	
24.0	4.9	5.0	5.2	4.9	4.6	4.3	3.6	3.2	
26.0	3.8	4.0	4.1	4.2	4.4	4.2	3.6	3.1	2.6
28.0	2.9	3.1	3.2	3.3	3.8	4.0	3.5	3.0	2.5
30.0	2.2	2.3	2.4	2.5	3.0	3.5	3.0	2.9	2.4
32.0	1.5	1.6	1.7	1.9	2.3	2.8	2.4	2.8	2.4
34.0					1.7	2.1		2.5	2.3
36.0						1.6		1.9	2.3
38.0									2.1
40.0									
θ (°)	58~77.5	59~82.7	59~82.7	61~80.5	61~82.7	61~82.7	65~82.7	65~82.7	66~82.7
標準フック	22t			7.3t					
フック質量	375kg			300kg					
標準巻掛本数	2			1					

注) カウンタウエイト25t、アウトリガ張出幅5.0m

■N性能

12.8mブーム+バイフォールドパワーチルトジブ

単位:t

ジブ長さ 作業半径 (m)	3.8m			10.2m			18m		
	オフセット			オフセット			オフセット		
	5°	20°	40°	5°	20°	40°	5°	20°	40°
3.0	40.0	32.7							
3.5	40.0	31.3	25.2				7.8		
4.0	40.0	30.0	24.5	14.6			7.8		
4.5	38.9	28.9	23.8	14.6			7.8		
5.0	36.8	27.8	23.2	14.6	14.1		7.8		
6.0	33.3	26.0	22.2	14.6	13.0		7.8		
7.0	30.4	24.4	21.3	14.6	12.1		7.5		
8.0	27.9	23.1	20.5	14.6	11.3	9.1	7.1		
9.0	22.6	22.0	19.9	13.8	10.6	8.7	6.7	5.2	
10.0	18.7	19.0	19.3	12.6	10.0	8.4	6.3	5.0	
11.0	15.8	16.0	16.1	11.4	9.4	8.0	6.0	4.7	
12.0	13.4	13.6		10.4	9.0	7.8	5.7	4.5	
14.0	10.0			8.9	8.2	7.3	5.1	4.1	3.5
16.0				7.8	7.6	7.0	4.6	3.8	3.3
18.0				6.9	7.1		4.2	3.5	3.1
20.0				6.1			3.9	3.3	3.0
22.0							3.5	3.1	2.9
24.0							3.3	3.0	2.8
26.0							3.1	2.9	
28.0							2.9		
30.0									
32.0									
34.0									
36.0									
38.0									
θ (°)	12~77.5	35~82.7	43~82.7	15~80.5	35~82.7	49~82.7	12~82.7	33~82.7	48~82.7
標準フック	50t			22t					
フック質量	600kg			375kg					
標準巻掛本数	6			2					

注) カウンタウエイト15t、アウトリガ張出幅5.0m

■N性能

25.8mブーム+バイフォールドパワーチルトジブ

単位:t

ジブ長さ 作業半径 (m)	3.8m			10.2m			18m		
	オフセット			オフセット			オフセット		
	5°	20°	40°	5°	20°	40°	5°	20°	40°
3.0									
3.5									
4.0									
4.5				34.4					
5.0				33.5					7.4
6.0				31.9	25.0				7.4
7.0	34.5	30.4	24.2	14.6	14.6				7.4
8.0	27.0	27.7	23.5	14.6	13.9				7.4
9.0	21.8	22.3	22.9	14.6	13.2				7.4
10.0	17.9	18.4	18.9	14.6	12.6	9.3	7.1		
11.0	15.0	15.4	15.9	14.6	12.0	9.0	6.9		
12.0	12.7	13.1	13.4	13.9	11.5	8.8	6.6	4.8	
14.0	9.3	9.6	9.9	10.5	10.6	8.3	6.1	4.4	
16.0	6.9	7.1	7.3	8.1	8.9	7.9	5.7	4.2	3.4
18.0	5.0	5.2	5.4	6.3	6.9	7.6	5.3	3.9	3.2
20.0	3.5	3.6	3.7	4.9	5.5	6.1	4.9	3.7	3.1
22.0	2.2	2.3	2.4	3.6	4.2	4.8	4.6	3.5	3.0
24.0	1.2	1.3		2.6	3.1	3.6	3.9	3.3	2.9
26.0				1.8	2.2	2.5	3.0	3.2	2.8
28.0				1.0	1.4		2.3	2.9	2.7
30.0							1.6	2.2	2.7
32.0							1.1	1.6	2.1
34.0								1.0	1.4
36.0									
38.0									
θ (°)	29~77.5	29~82.7	40~82.7	33~80.5	37~82.7	45~82.7	40~82.7	41~82.7	45~82.7
標準フック	50t			22t					
フック質量	600kg			375kg					
標準巻掛本数	5			2					

注) カウンタウエイト15t、アウトリガ張出幅5.0m

■N性能

34.4mブーム+バイフォールドパワーチルトジブ

単位:t

ジブ長さ 作業半径 (m)	3.8m			10.2m			18m		
	オフセット			オフセット			オフセット		
	5°	20°	40°	5°	20°	40°	5°	20°	40°
3.0									
3.5									
4.0									
4.5									
5.0									
6.0									
7.0		17.8	16.3				5.9		
8.0		16.9	15.6	13.4			5.9		
9.0	17.4	16.2	15.0	13.4	12.1		5.9		
10.0	16.6	15.5	14.4	13.4	11.5		5.9		
11.0	15.9	14.9	13.9	12.9	11.0		5.9		
12.0	13.9	14.2	13.4	12.4	10.6	9.0	5.9		
14.0	10.4	10.7	11.0	11.0	9.8	8.5	5.9	4.3	
16.0	8.0	8.2	8.4	8.6	9.1	8.0	5.7	4.1	
18.0	6.2	6.4	6.5	6.8	7.4	7.6	5.4	3.9	3.2
20.0	4.7	4.9	5.1	5.4	6.0	6.6	5.1	3.7	3.0
22.0	3.5	3.6	3.8	4.2	4.8	5.3	4.0	3.6	2.9
24.0	2.4	2.6	2.7	3.2	3.7	4.3	4.2	3.4	2.9
26.0	1.6	1.7	1.8	2.3	2.8	3.3	3.4	3.3	2.8
28.0	0.9	1.0		1.6	2.0	2.4	2.6	3.1	2.7
30.0				1.0	1.4	1.7	2.0	2.7	2.6
32.0					0.8	1.0	1.4	2.0	2.6
34.0							1.0	1.5	2.0
36.0								1.0	1.5
38.0									1.0
θ (°)	39~77.5	40~82.7	45~82.7	44~80.5	43~82.7	45~82.7	48~82.7	49~82.7	50~82.7
標準フック	50t			22t			7.3t		
フック質量	600kg			375kg			300kg		
標準巻掛本数	3			2			1		

注) カウンタウエイト15t、アウトリガ張出幅5.0m

■N性能

43.0mブーム+バイフォールドパワーチルトジブ

単位:t

ジブ長さ 作業半径 (m)	3.8m			10.2m			18m		
	オフセット			オフセット			オフセット		
	5°	20°	40°	5°	20°	40°	5°	20°	40°
3.0									
3.5									
4.0									
4.5									
5.0									
6.0									
7.0									
8.0									
9.0		14.6	13.6						
10.0		14.0	13.1					5.5	
11.0		13.4	12.6	10.6				5.5	
12.0	13.2	12.9	12.2	10.6	9.8			5.5	
14.0	9.8	10.1	10.4	10.3	9.2	8.0		5.5	
16.0	7.4	7.6	7.9	7.8	8.6	7.6		5.5	4.1
18.0	5.5	5.8	6.0	6.1	6.8	7.2	5.4	3.9	
20.0	4.0	4.2	4.4	4.6	5.3	6.1	5.2	3.7	3.0
22.0	2.7	2.9	3.1	3.3	4.0	4.8	4.4	3.6	2.9
24.0	1.7	1.9	2.0	2.3	3.0	3.7	3.4	3.4	2.8
26.0					2.0	2.7	2.5	3.3	2.7
28.0						1.8		2.7	2.7
30.0								1.9	2.6
32.0									2.1
34.0									
36.0									
38.0									
θ (°)	57~77.5	58~82.7	58~82.7	61~80.5	61~82.7	61~82.7	64~82.7	63~82.7	65~82.7
標準フック	50t			22t			7.3t		
フック質量	600kg			375kg			300kg		
標準巻掛本数	3			2			1		

注) カウンタウエイト15t、アウトリガ張出幅5.0m

■N性能

56.0mブーム+バイフォールドパワーチルトジブ

単位:t

ジブ長さ 作業半径 (m)	3.8m			10.2m			18m		
	オフセット			オフセット			オフセット		
	5°	20°	40°	5°	20°	40°	5°	20°	40°
3.0									
3.5									
4.0									
4.5									
5.0									
6.0									
7.0									
8.0									
9.0									
10.0									
11.0									
12.0			8.8						
14.0		8.3	8.0					3.9	
16.0		7.8	7.6	6.4	6.1			3.9	
18.0	6.3	6.5	6.7	6.3	5.8	5.4		3.9	
20.0	4.8	5.0	5.3	5.2	5.5	5.1	3.9	3.5	
22.0	3.5	3.8	4.0	4.0	4.7	4.9	3.9	3.4	
24.0	2.5	2.7	2.9	2.9	3.6	4.3	3.5	3.3	2.7
26.0					2.7	3.3	2.7	3.2	2.6
28.0						2.5		2.9	2.5
30.0									2.5
32.0									2.4
34.0									
36.0									
38.0									
θ (°)	65~77.5	65~82.7	66~82.7	67~80.5	67~82.7	68~82.7	69~82.7	70~82.7	70~82.7
標準フック	22t			7.3t					
フック質量	375kg			300kg					
標準巻掛本数	2			1					

注) カウンタウエイト15t、アウトリガ張出幅5.0m

■N性能

60.0mブーム+バイフォールドパワーチルトジブ

単位:t

ジブ長さ 作業半径 (m)	3.8m			10.2m			18m		
	オフセット			オフセット			オフセット		
	5°	20°	40°	5°	20°	40°	5°	20°	40°
3.0									
3.5									
4.0									
4.5									
5.0									
6.0									
7.0									
8.0									
9.0									
10.0									
11.0									
12.0									
14.0					7.5	7.3			
16.0					7.1	6.9	5.7	5.6	3.6
18.0	6.3	6.5	6.6	6.3	5.7	5.3			3.6
20.0	4.8	5.0	5.2	5.2	5.1	4.7			3.6
22.0	3.5	3.7	3.9	3.9	4.6	4.5	3.6	3.3	
24.0		2.7	2.9	2.9	3.5	4.3	3.5	3.2	
26.0						3.3		3.1	2.6
28.0								2.8	2.5
30.0									2.4
32.0									
34.0									
36.0									
38.0									
θ (°)	68~77.5	67~82.7	68~82.7	69~80.5	71~82.7	71~82.7	71~82.7	71~82.7	73~82.7
標準フック	22t			7.3t					
フック質量	375kg			300kg					
標準巻掛本数	2			1					

注) カウンタウエイト15t、アウトリガ張出幅5.0m

■O性能

12.8mブーム+バイフォールドパワーチルトジブ

単位:t

ジブ長さ 作業半径 (m)	3.8m			10.2m			18m		
	オフセット			オフセット			オフセット		
	5°	20°	40°	5°	20°	40°	5°	20°	40°
3.0	40.0	32.7							
3.5	40.0	31.3	25.2				7.8		
4.0	40.0	30.0	24.5	14.6			7.8		
4.5	38.9	28.9	23.8	14.6			7.8		
5.0	36.8	27.8	23.2	14.6	14.1		7.8		
6.0	33.3	26.0	22.2	14.6	13.0		7.8		
7.0	26.6	24.4	21.3	14.6	12.1		7.5		
8.0	20.6	21.1	20.5	14.6	11.3	9.1	7.1		
9.0	16.4	16.8	17.2	13.8	10.6	8.7	6.7	5.2	
10.0	13.4	13.7	13.9	12.6	10.0	8.4	6.3	5.0	
11.0	11.0	11.3	11.4	11.4	9.4	8.0	6.0	4.7	
12.0	9.2	9.4		10.4	9.0	7.8	5.7	4.5	
14.0	6.5			8.5	8.2	7.3	5.1	4.1	3.5
16.0				6.6	7.0	7.0	4.6	3.8	3.3
18.0				5.1	5.4		4.2	3.5	3.1
20.0				4.0			3.9	3.3	3.0
22.0							3.5	3.1	2.9
24.0							3.3	3.0	2.8
26.0							2.9	2.9	
28.0							2.4		
30.0									
$\theta$ (°)	12~77.5	35~82.7	43~82.7	15~80.5	35~82.7	49~82.7	12~82.7	33~82.7	48~82.7
標準フック	50t			22t					
フック質量	600kg			375kg					
標準巻掛本数	6			2					

注) カウンタウエイト6t、アウトリガ張出幅5.0m

■O性能

25.8mブーム+バイフォールドパワーチルトジブ

単位:t

ジブ長さ 作業半径 (m)	3.8m			10.2m			18m		
	オフセット			オフセット			オフセット		
	5°	20°	40°	5°	20°	40°	5°	20°	40°
3.0									
3.5									
4.0									
4.5				34.4					
5.0				33.5					7.4
6.0				31.9	25.0				7.4
7.0	25.6	26.5	24.2	14.6	14.6				7.4
8.0	19.7	20.4	21.1	14.6	13.9				7.4
9.0	15.6	16.2	16.8	14.6	13.2				7.4
10.0	12.6	13.1	13.6	13.9	12.6	9.3	7.1		
11.0	10.3	10.7	11.1	11.5	12.0	9.0	6.9		
12.0	8.5	8.9	9.2	9.7	10.9	8.8	6.6	4.8	
14.0	5.8	6.1	6.4	7.0	8.0	8.3	6.1	4.4	
16.0	3.7	4.0	4.2	5.1	5.9	6.8	5.7	4.2	3.4
18.0	2.1	2.3	2.5	3.6	4.4	5.1	4.8	3.9	3.2
20.0	0.9	1.1	1.2	2.3	3.0	3.8	3.7	3.7	3.1
22.0							2.6	3.5	3.0
24.0				1.3	1.9	2.5	2.6	2.7	2.9
26.0					1.0	1.5	1.8	2.7	2.8
28.0							1.1	1.9	2.8
30.0								1.2	2.0
$\theta$ (°)	43~77.5	44~82.7	44~82.7	48~80.5	47~82.7	51~82.7	51~82.7	53~82.7	54~82.7
標準フック	50t			22t					
フック質量	600kg			375kg					
標準巻掛本数	5			2					

注) カウンタウエイト6t、アウトリガ張出幅5.0m

■O性能

34.4mブーム+バイフォールドパワーチルトジブ

単位:t

ジブ長さ 作業半径 (m)	3.8m			10.2m			18m		
	オフセット			オフセット			オフセット		
	5°	20°	40°	5°	20°	40°	5°	20°	40°
3.0									
3.5									
4.0									
4.5									
5.0									
6.0									
7.0		17.8	16.3				5.9		
8.0		16.9	15.6	13.4			5.9		
9.0	16.9	16.2	15.0	13.4	12.1		5.9		
10.0	13.9	14.3	14.4	13.4	11.5		5.9		
11.0	11.5	11.9	12.3	12.1	11.0		5.9		
12.0	9.7	10.0	10.4	10.3	10.6	9.0	5.9		
14.0	6.9	7.2	7.5	7.5	8.5	8.5	5.9	4.3	
16.0	5.0	5.2	5.5	5.6	6.4	7.3	5.7	4.1	
18.0	3.4	3.7	3.9	4.2	4.9	5.6	5.2	3.9	3.2
20.0	2.2	2.4	2.5	2.9	3.6	4.3	4.0	3.7	3.0
22.0		1.3	1.5	1.9	2.5	3.2	3.0	3.6	2.9
24.0					1.6	2.2	2.2	3.1	2.9
26.0						1.4		2.3	2.8
28.0								1.6	2.5
30.0									1.8
θ (°)	56~77.5	53~82.7	53~82.7	58~80.5	57~82.7	57~82.7	62~82.7	61~82.7	63~82.7
標準フック	50t			22t			7.3t		
フック質量	600kg			375kg			300kg		
標準巻掛本数	3			2			1		

注) カウンタウエイト6t、アウトリガ張出幅5.0m

■O性能

43.0mブーム+バイフォールドパワーチルトジブ

単位:t

ジブ長さ 作業半径 (m)	3.8m			10.2m			18m		
	オフセット			オフセット			オフセット		
	5°	20°	40°	5°	20°	40°	5°	20°	40°
3.0									
3.5									
4.0									
4.5									
5.0									
6.0									
7.0									
8.0									
9.0				14.6	13.6				
10.0		13.6	13.1					5.5	
11.0		11.3	11.7	10.6				5.5	
12.0	9.0	9.4	9.8	9.5	9.8			5.5	
14.0	6.3	6.6	6.9	6.8	7.8	8.0		5.5	
16.0	4.2	4.6	4.9	4.8	5.8	6.8		5.5	4.1
18.0				3.2		4.2	5.1	4.4	3.9
20.0							3.8	3.2	3.7
22.0									3.4
24.0									2.8
26.0									2.7
28.0									
30.0									
θ (°)	68~77.5	69~82.7	67~82.7	71~80.5	71~82.7	71~82.7	70~82.7	72~82.7	72~82.7
標準フック	50t			22t			7.3t		
フック質量	600kg			375kg			300kg		
標準巻掛本数	3			2			1		

注) カウンタウエイト6t、アウトリガ張出幅5.0m

■Q性能

12.8mブーム+バイフォールドパワーチルトジブ

単位:t

ジブ長さ 作業半径 (m)	3.8m			10.2m			18m		
	オフセット			オフセット			オフセット		
	5°	20°	40°	5°	20°	40°	5°	20°	40°
3.0	40.0	32.7							
3.5	40.0	31.3	25.2				7.8		
4.0	40.0	30.0	24.5	14.6			7.8		
4.5	38.9	28.9	23.8	14.6			7.8		
5.0	36.8	27.8	23.2	14.6	14.1		7.8		
6.0	33.3	26.0	22.2	14.6	13.0		7.8		
7.0	27.5	24.4	21.3	14.6	12.1		7.5		
8.0	21.8	22.3	20.5	14.6	11.3	9.1	7.1		
9.0	17.7	18.1	18.4	13.8	10.6	8.7	6.7	5.2	
10.0	14.7	15.0	15.2	12.6	10.0	8.4	6.3	5.0	
11.0	12.3	12.6	12.7	11.4	9.4	8.0	6.0	4.7	
12.0	10.4	10.6		10.4	9.0	7.8	5.7	4.5	
14.0	7.6			8.9	8.2	7.3	5.1	4.1	3.5
16.0				7.5	7.6	7.0	4.6	3.8	3.3
18.0				6.0	6.3		4.2	3.5	3.1
20.0				4.8			3.9	3.3	3.0
22.0							3.5	3.1	2.9
24.0							3.3	3.0	2.8
26.0							3.1	2.9	
28.0							2.9		
30.0									
32.0									
34.0									
θ (°)	12~77.5	35~82.7	43~82.7	15~80.5	35~82.7	49~82.7	12~82.7	33~82.7	48~82.7
標準フック	50t			22t			22t		
フック質量	600kg			375kg			375kg		
標準巻掛本数	6			2			2		

注) カウンタウエイト15t、アウトリガ張出幅4.1m

■Q性能

25.8mブーム+バイフォールドパワーチルトジブ

単位:t

ジブ長さ 作業半径 (m)	3.8m			10.2m			18m		
	オフセット			オフセット			オフセット		
	5°	20°	40°	5°	20°	40°	5°	20°	40°
3.0									
3.5									
4.0									
4.5		34.4							
5.0		33.5						7.4	
6.0		31.9	25.0					7.4	
7.0	26.6	27.4	24.2	14.6	14.6			7.4	
8.0	21.0	21.6	22.3	14.6	13.9			7.4	
9.0	17.0	17.5	18.1	14.6	13.2			7.4	
10.0	14.0	14.4	14.9	14.6	12.6	9.3	7.1		
11.0	11.6	12.0	12.4	12.8	12.0	9.0	6.9		
12.0	9.8	10.1	10.5	10.9	11.5	8.8	6.6	4.8	
14.0	7.0	7.2	7.5	8.1	9.1	8.3	6.1	4.4	
16.0	4.9	5.1	5.4	6.1	6.9	7.8	5.7	4.2	3.4
18.0	3.2	3.4	3.5	4.6	5.3	6.0	5.3	3.9	3.2
20.0	1.9	2.0	2.1	3.2	3.9	4.6	4.5	3.7	3.1
22.0	0.8	0.9	1.0	2.2	2.8	3.3	3.4	3.5	3.0
24.0				1.3	1.8	2.3	2.5	3.3	2.9
26.0					1.0	1.3	1.8	2.6	2.8
28.0							1.2	1.8	2.6
30.0								1.2	1.8
32.0									1.2
34.0									
θ (°)	36~77.5	37~82.7	40~82.7	44~80.5	42~82.7	45~82.7	48~82.7	49~82.7	50~82.7
標準フック	50t			22t			22t		
フック質量	600kg			375kg			375kg		
標準巻掛本数	5			2			2		

注) カウンタウエイト15t、アウトリガ張出幅4.1m



■Q性能

34.4mブーム+バイフォールドパワーチルトジブ

単位:t

ジブ長さ 作業半径 (m)	3.8m			10.2m			18m		
	オフセット			オフセット			オフセット		
	5°	20°	40°	5°	20°	40°	5°	20°	40°
3.0									
3.5									
4.0									
4.5									
5.0									
6.0									
7.0		17.8	16.3				5.9		
8.0		16.9	15.6	13.4			5.9		
9.0	17.4	16.2	15.0	13.4	12.1		5.9		
10.0	15.2	15.5	14.4	13.4	11.5		5.9		
11.0	12.8	13.2	13.5	12.9	11.0		5.9		
12.0	10.9	11.2	11.6	11.5	10.6	9.0	5.9		
14.0	8.1	8.3	8.6	8.6	9.5	8.5	5.9	4.3	
16.0	6.0	6.3	6.5	6.6	7.4	8.0	5.7	4.1	
18.0	4.4	4.7	4.9	5.1	5.7	6.5	5.4	3.9	3.2
20.0	3.1	3.3	3.4	3.8	4.5	5.1	4.8	3.7	3.0
22.0	2.0	2.2	2.3	2.8	3.4	4.0	3.8	3.6	2.9
24.0	1.1	1.3	1.4	1.9	2.4	3.0	2.9	3.4	2.9
26.0				1.2	1.6	2.1	2.2	3.0	2.8
28.0					0.9	1.3	1.5	2.3	2.7
30.0								1.6	2.4
32.0								1.1	1.7
34.0									1.2
θ (°)	48~77.5	49~82.7	49~82.7	51~80.5	51~82.7	53~82.7	56~82.7	55~82.7	57~82.7
標準フック	50t			22t			7.3t		
フック質量	600kg			375kg			300kg		
標準巻掛本数	3			2			1		

注) カウンタウエイト15t、アウトリガ張出幅4.1m

■Q性能

43.0mブーム+バイフォールドパワーチルトジブ

単位:t

ジブ長さ 作業半径 (m)	3.8m			10.2m			18m		
	オフセット			オフセット			オフセット		
	5°	20°	40°	5°	20°	40°	5°	20°	40°
3.0									
3.5									
4.0									
4.5									
5.0									
6.0									
7.0									
8.0									
9.0		14.6	13.6						
10.0		14.0	13.1					5.5	
11.0		12.5	12.6	10.6				5.5	
12.0	10.2	10.6	11.0	10.6	9.8			5.5	
14.0	7.4	7.7	8.0	7.9	8.9	8.0		5.5	
16.0	5.4	5.7	5.9	5.9	6.8	7.6	5.5	4.1	
18.0	3.7	3.9	4.2	4.3	5.1	6.0	5.3	3.9	
20.0	2.3	2.6	2.8	2.9	3.8	4.6	4.1	3.7	3.0
22.0					2.6	3.4	3.0	3.6	2.9
24.0						2.3		3.2	2.8
26.0								2.3	2.7
28.0									2.6
30.0									
32.0									
34.0									
θ (°)	63~77.5	63~82.7	64~82.7	66~80.5	66~82.7	66~82.7	68~82.7	68~82.7	70~82.7
標準フック	50t			22t			7.3t		
フック質量	600kg			375kg			300kg		
標準巻掛本数	3			2			1		

注) カウンタウエイト15t、アウトリガ張出幅4.1m

### 3. 作業半径—揚程図

56.0mブーム

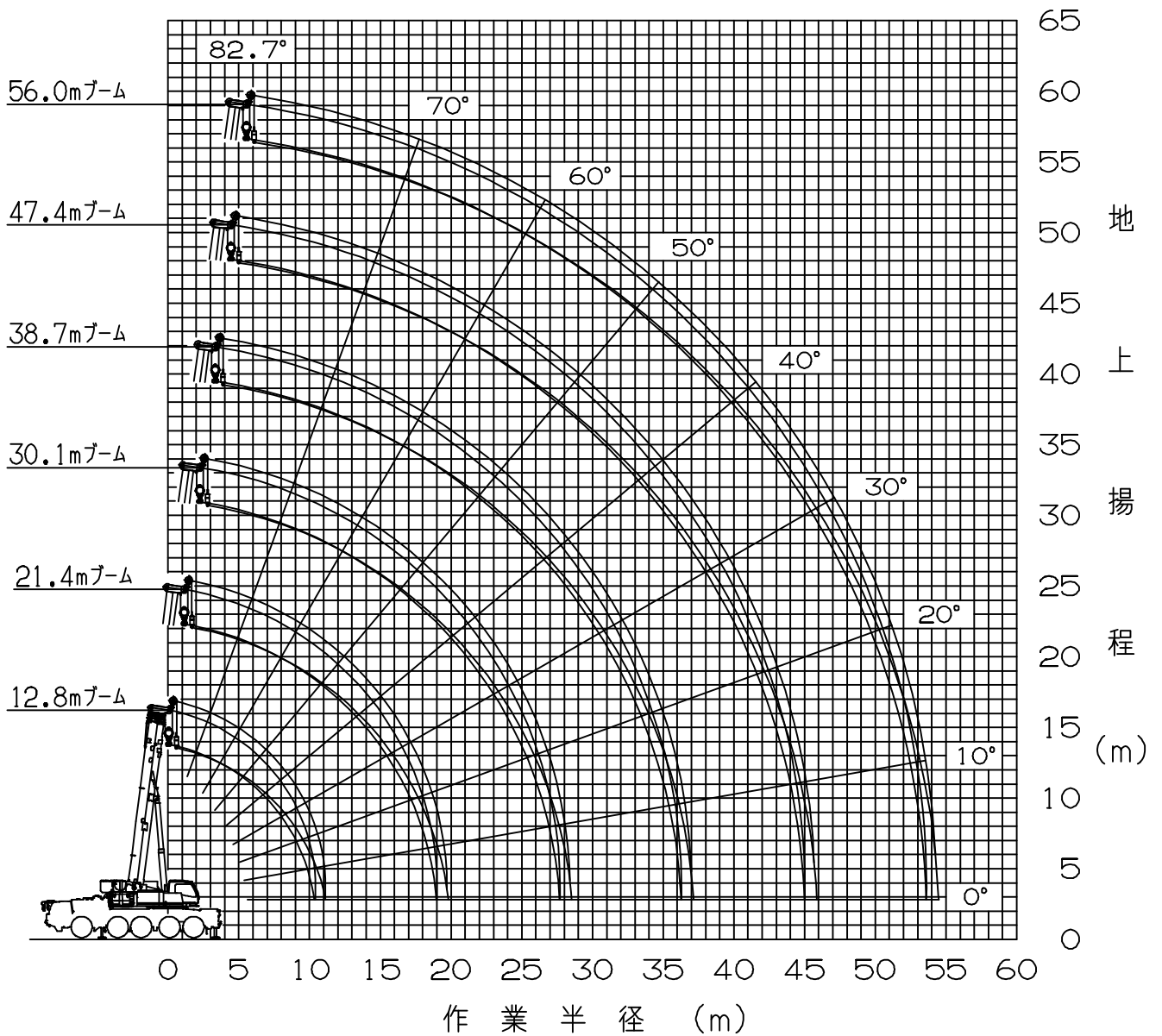

- (注) 1. 上記はブームのたわみを含んでいません。  
 2. A, F性能の最大作業半径を図示しています。

60.0mブーム

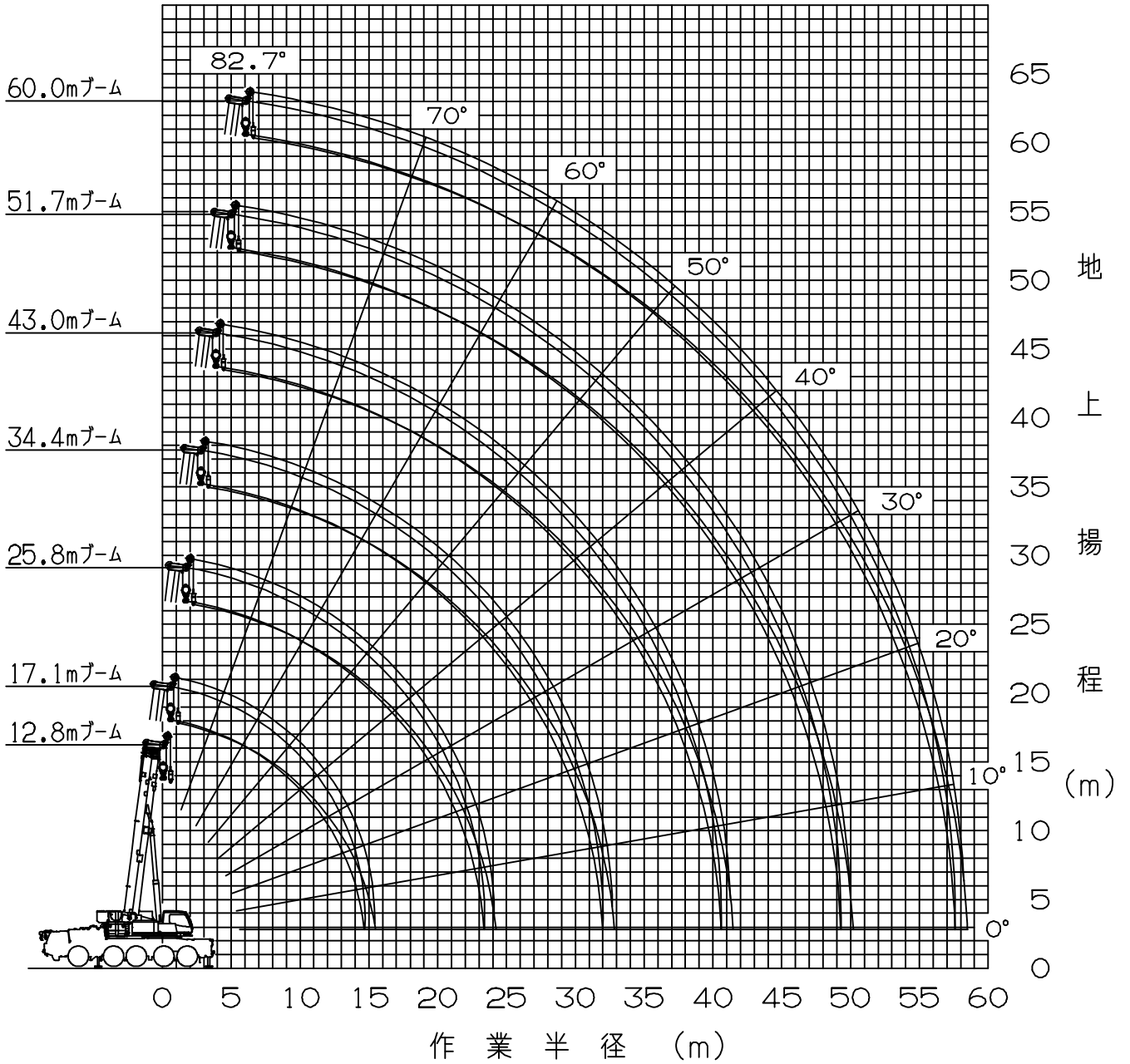

- (注) 1. 上記はブームのたわみを含んでいません。  
 2. A, F性能の最大作業半径を図示しています。

12. 8mブーム+バイフォールドジブ

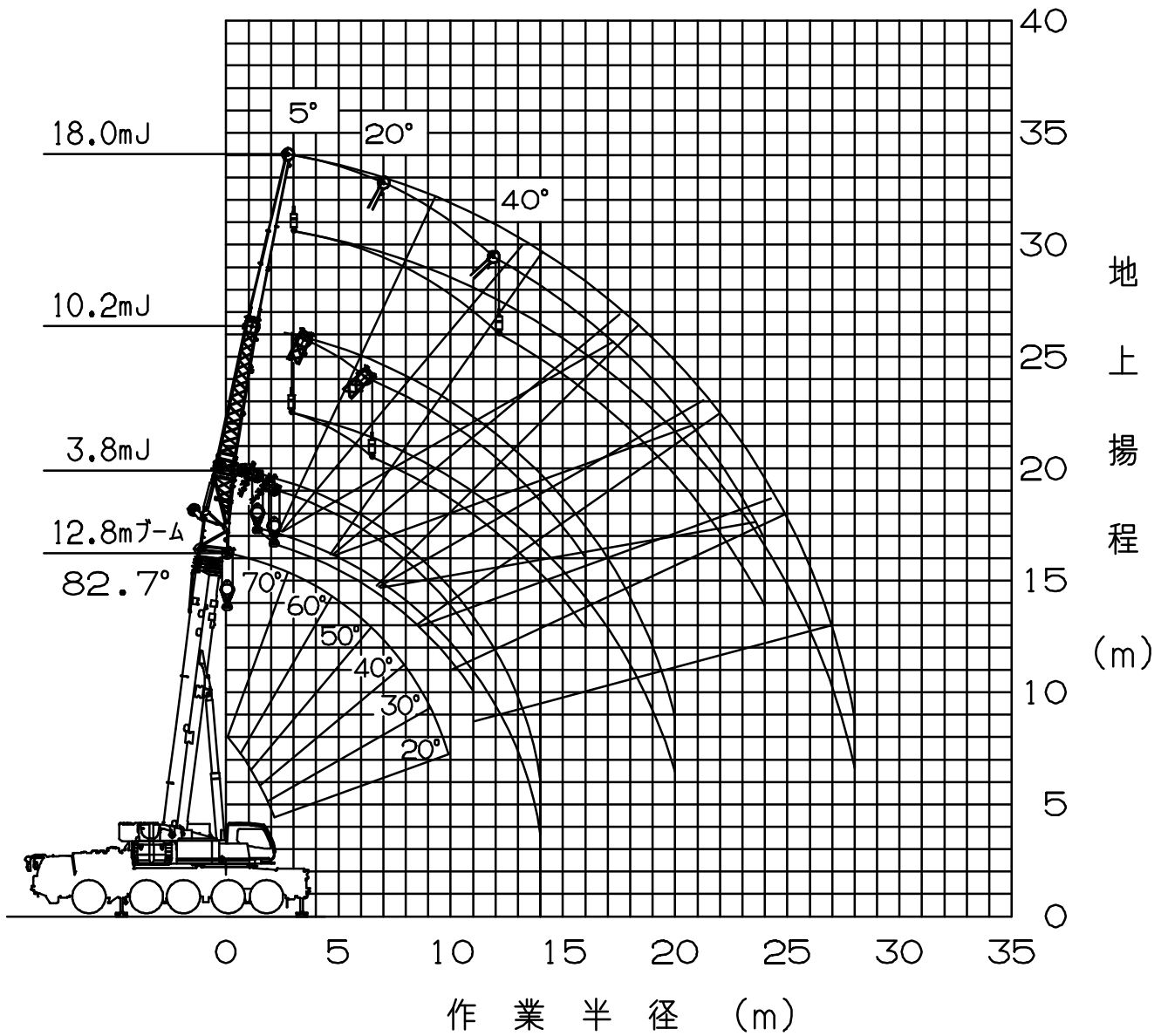

- (注) 1. 上記はブームおよびジブのたわみを含んでいません。  
 2. A性能の最大作業半径を図示しています。

25. 8mブーム+バイフォールドジブ

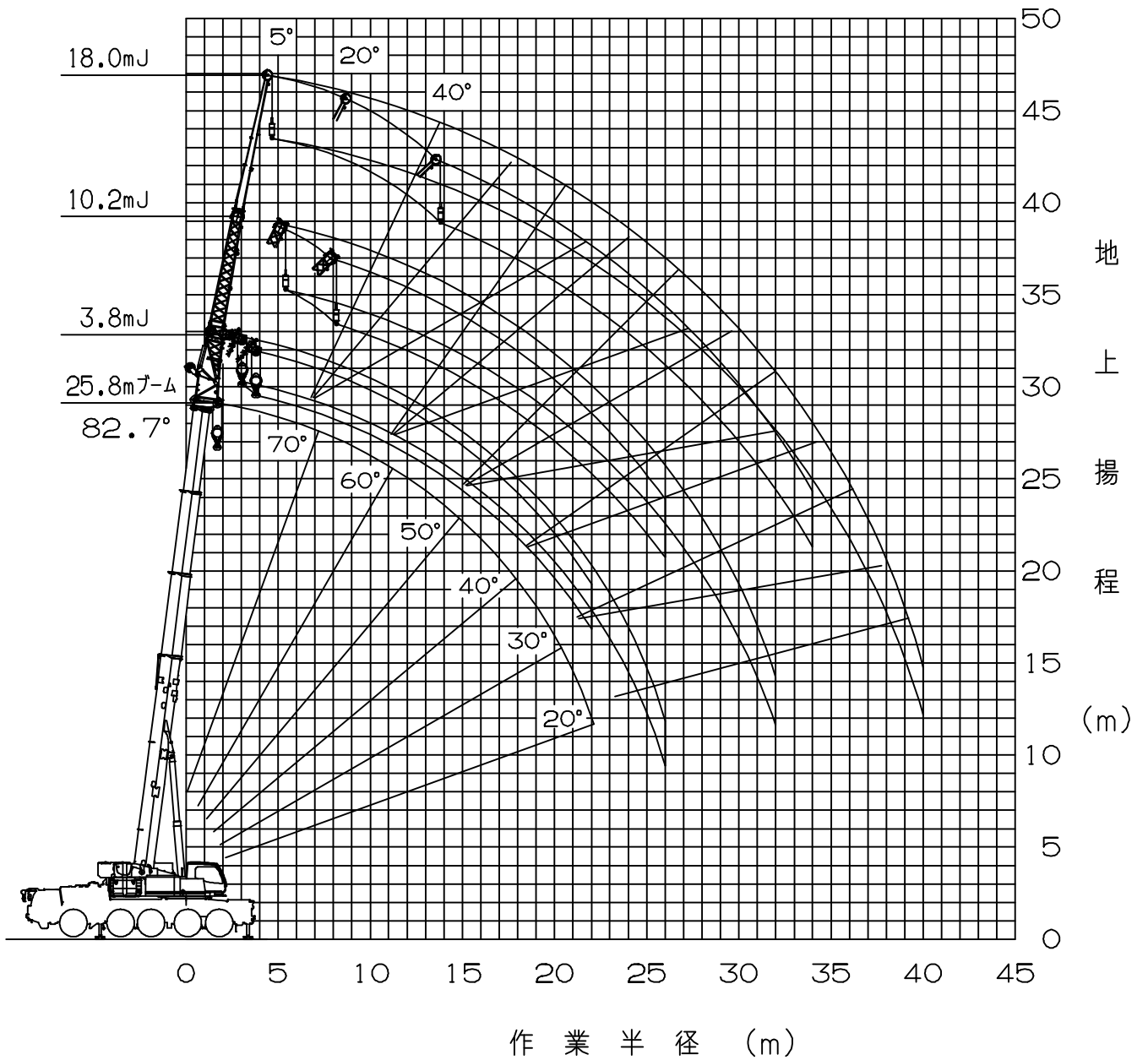

- (注) 1. 上記はブームおよびジブのたわみを含んでいません。  
 2. A性能の最大作業半径を図示しています。

### 3 4. 4 mブーム+バイフォールドジブ

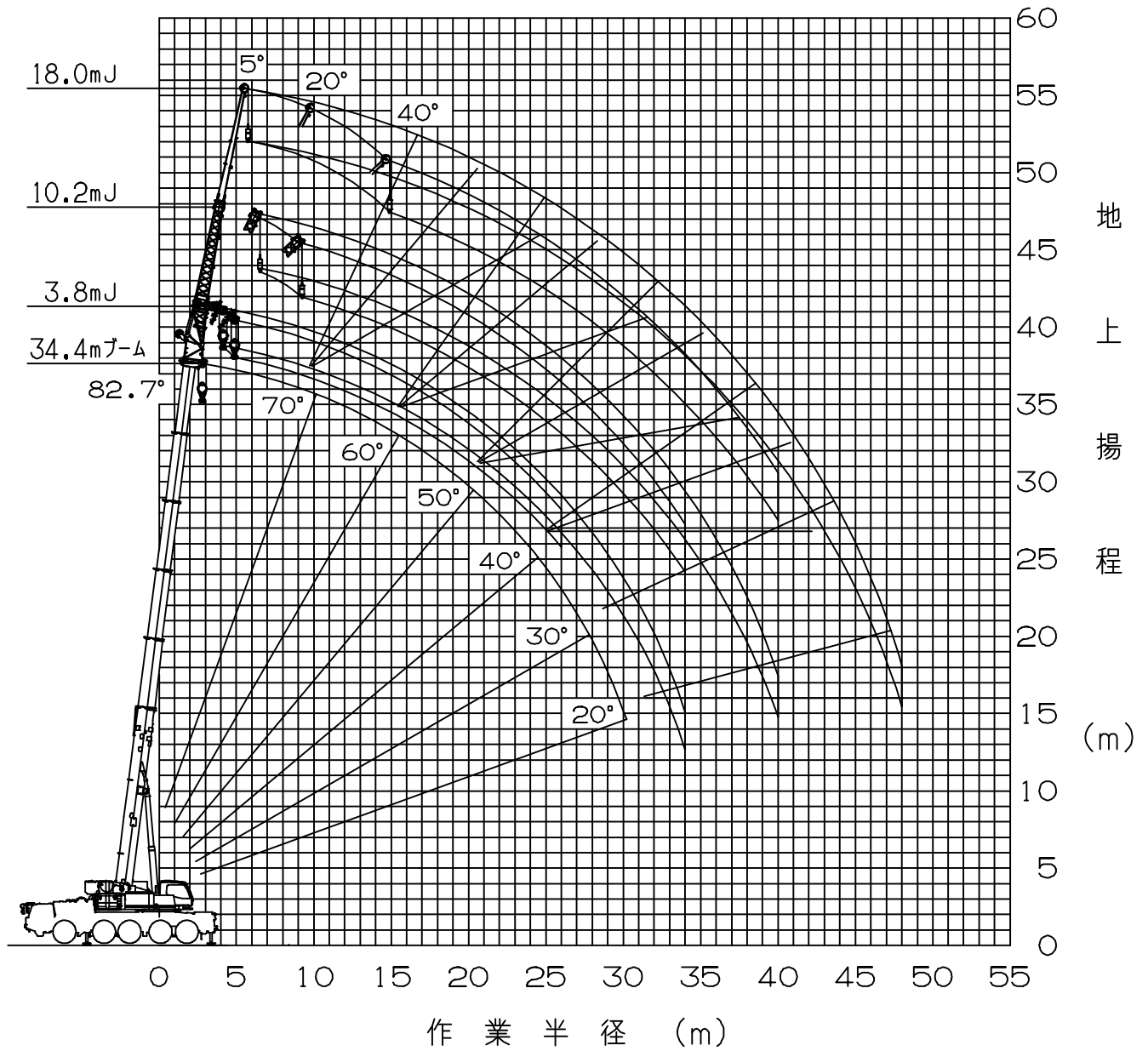

- (注) 1. 上記はブームおよびジブのたわみを含んでいません。  
 2. A性能の最大作業半径を図示しています。

4 3. 0 mブーム+バイフォールドジブ

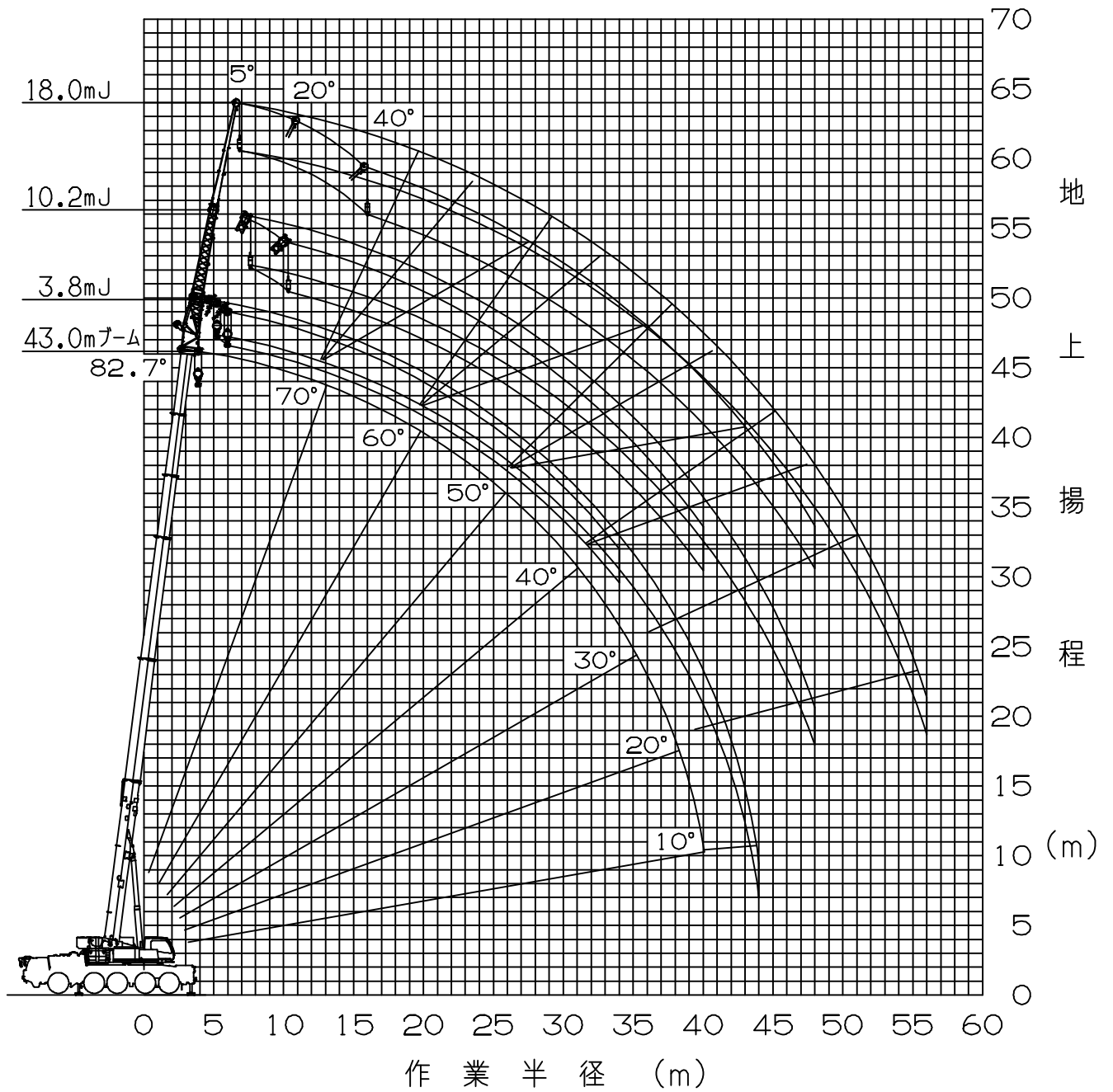

- (注) 1. 上記はブームおよびジブのたわみを含んでいません。  
 2. A性能の最大作業半径を図示しています。

56. 0mブーム+バイフォールドジブ

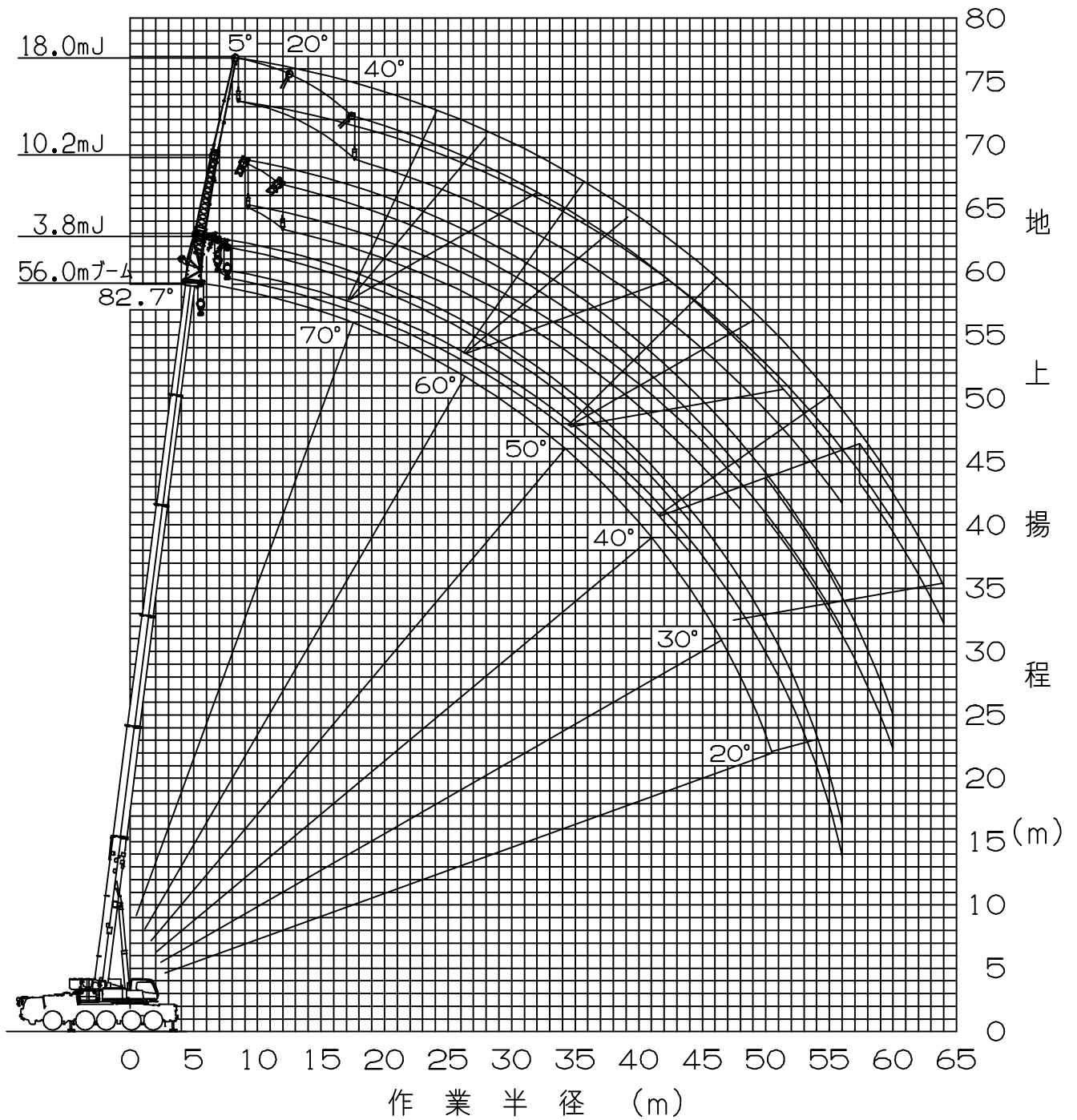

- (注) 1. 上記はブームおよびジブのたわみを含んでいません。  
 2. A性能の最大作業半径を図示しています。



60.0mブーム+バイフォールドジブ

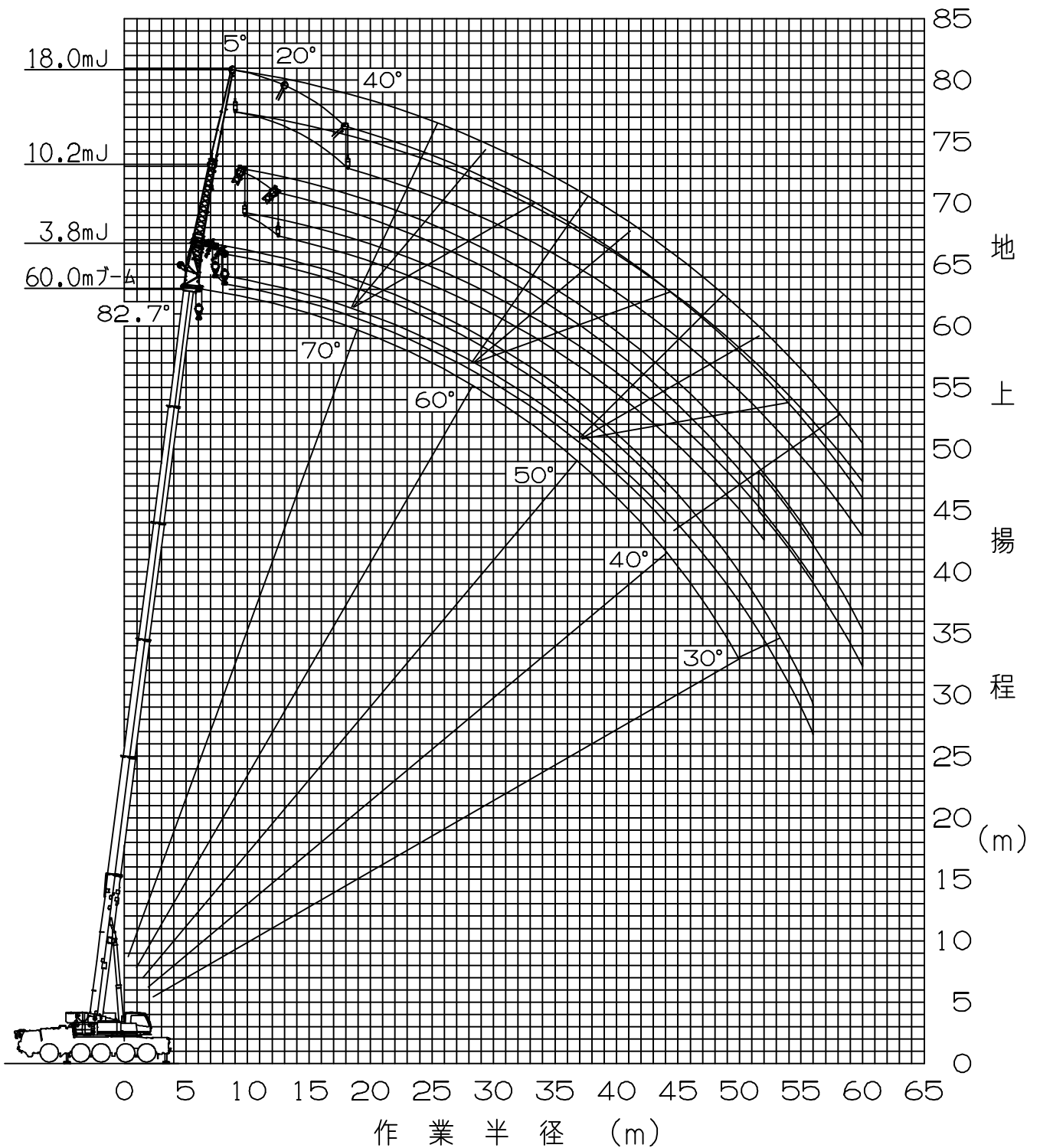

- (注) 1. 上記はブームおよびジブのたわみを含んでいません。  
 2. A性能の最大作業半径を図示しています。

#### 4. 外観図

[公道走行状態]

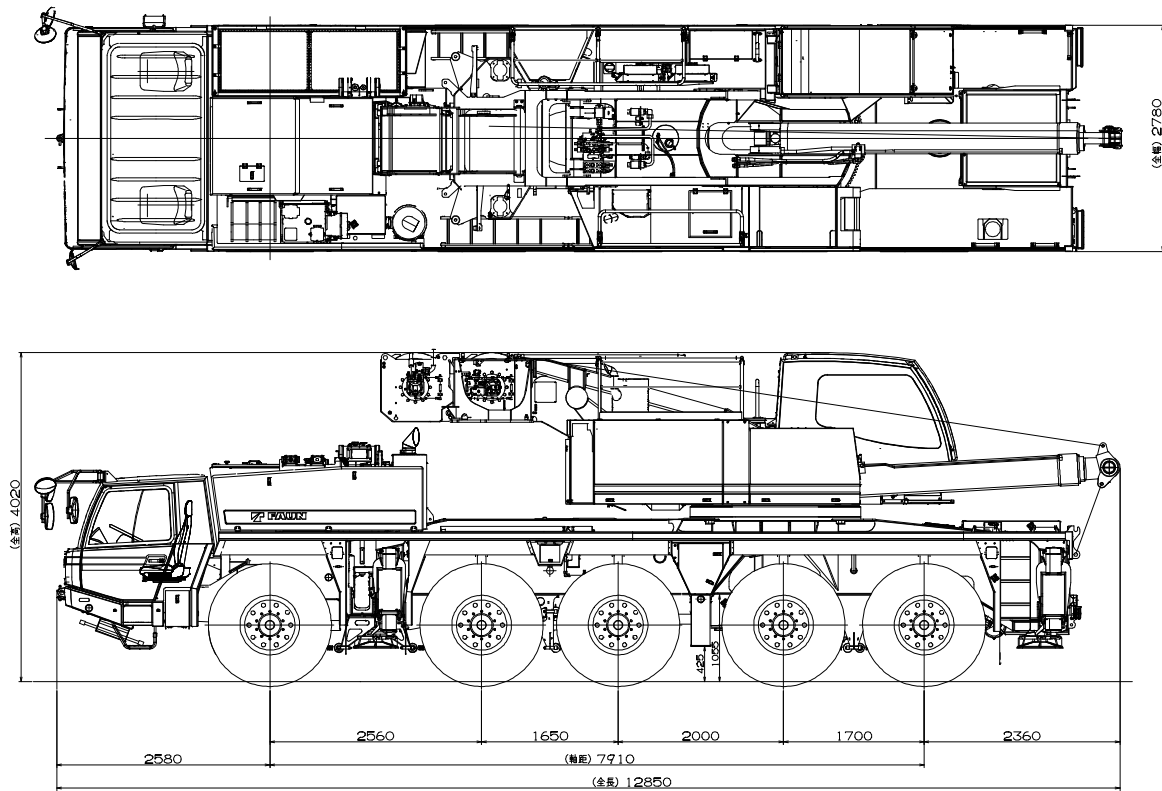

[構内走行状態]

